

W22 Brake Motor

Three-phase Electric Motor

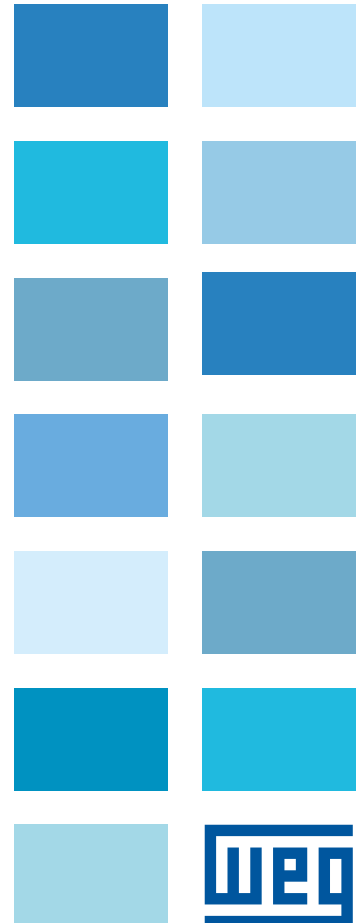

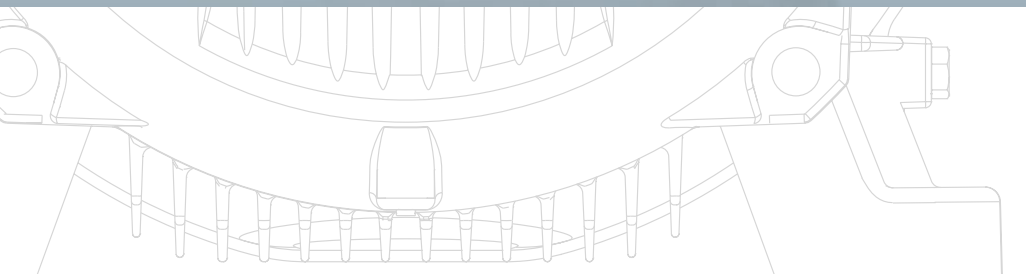
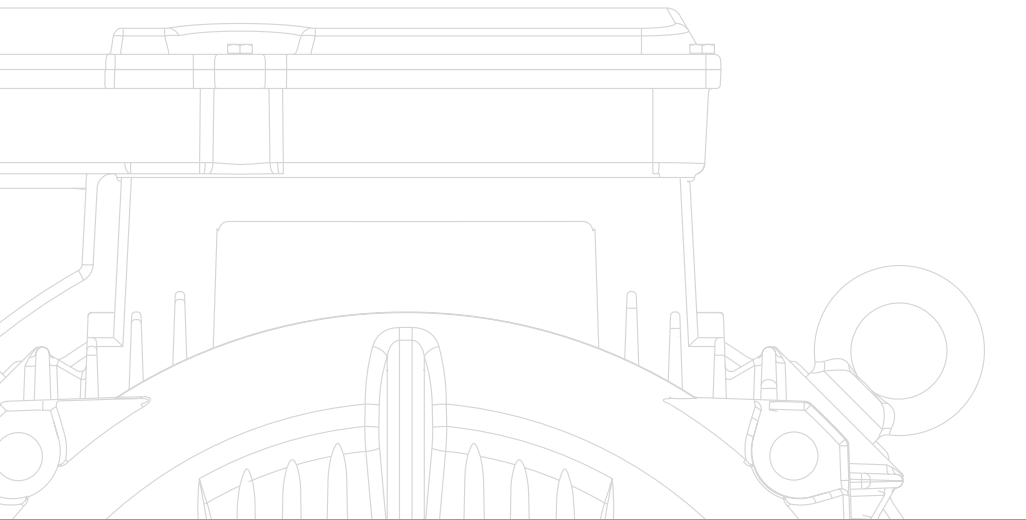

Efficiency and reliability for the industry

Founded in 1961, WEG is recognized today as one of the world's largest electric motors manufacturer, present in more than 100 countries at the five continents and counting on more than 25,000 employees, producing more than 10 million motors per year. Offering a wide range of motors, WEG also stands out in the supply of dedicated applications. Always focused on the customer's needs, it offers solutions for many different applications. WEG motors provide high efficiency, low operating costs, extended service life, and, above all, safety!

Visual index

Main motor parts

1	Sealing system	8	Fan
2	Endshields	9	Bridge rectifier
3	Bearings	10	Terminal block
4	Shaft	11	Terminal box
5	Rotor	12	Frame
6	Eyebolt	13	Stator
7	Fan cover	14	Shaft key

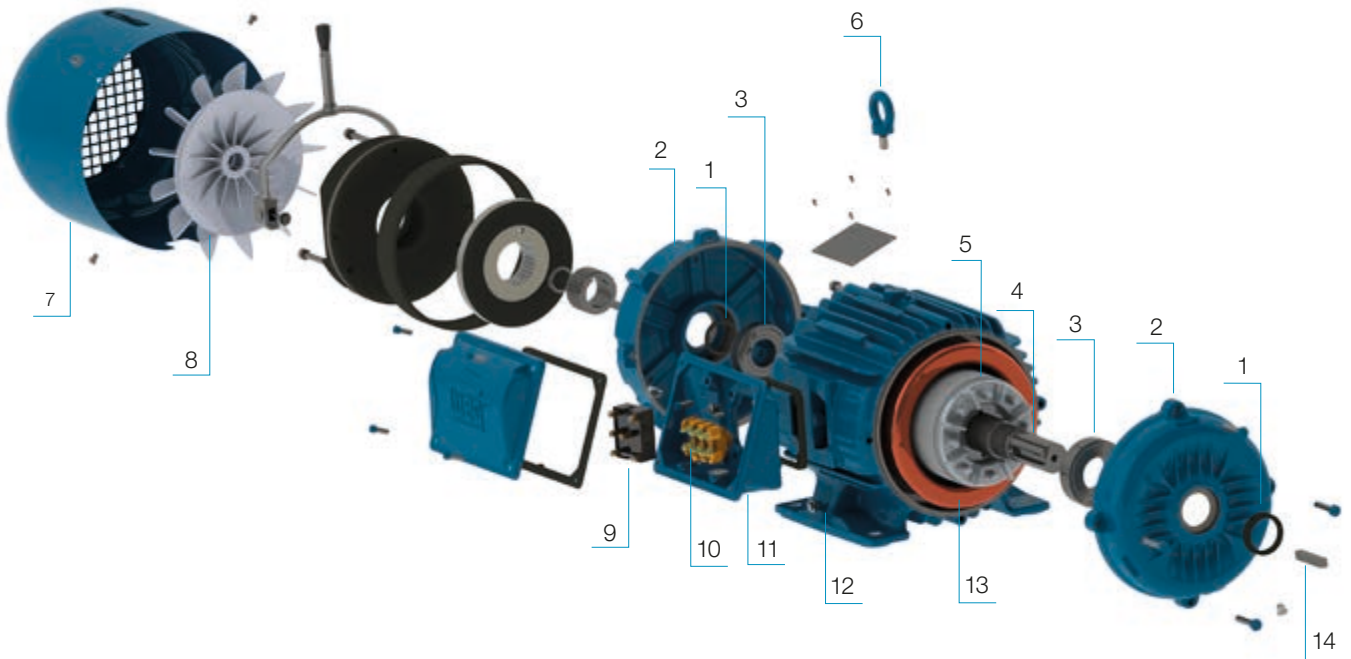

Main brake parts

1	Fastening screw	6	Retaining ring
2	Release lever	7	Hub
3	Brake stator (electromagnet)	8	Key
4	Brake disc	9	Sealing system
5	Brake seal	10	ND-endshield

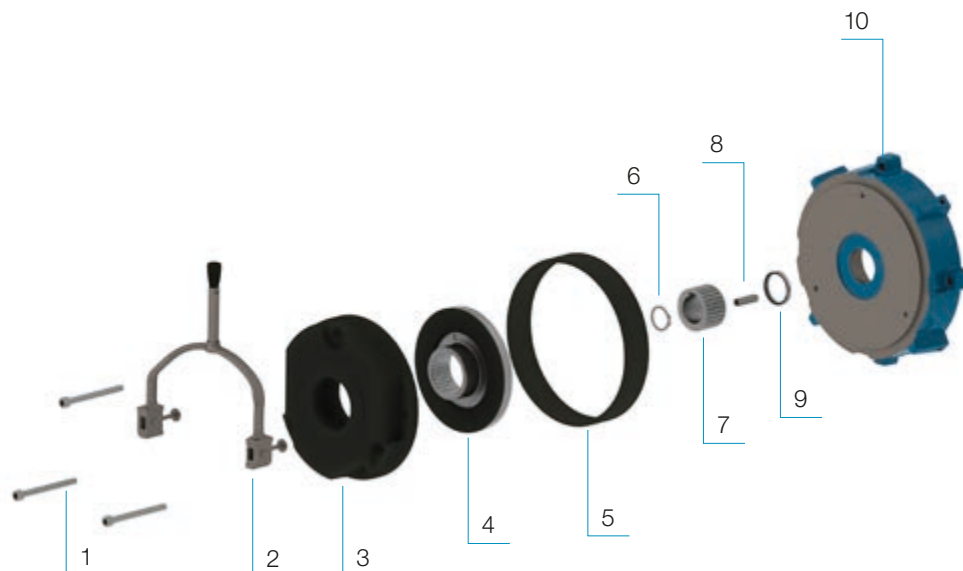

W22 Brake Motor: new platform, new brake, excellent performance!

In order to obtain productivity and high performance, a company must count on reliable equipment, operating in accordance with its purpose. That is the essence of the W22 brake motor: provide the production process with synergy and agility.

Featuring a new braking system, high torque and durability, the W22 brake motor is ideal for equipment that requires fast stops for safety, accurate positioning and time saving.



The new brake motor introduces new characteristics in the braking system and platform, which now counts on the same innovative features that make the W22 line a great success:

- Frame structure that reduces air dispersion and improves the cooling
- Terminal box with greater internal space and easy handling
- Solid feet that simplify the motor alignment and installation
- Frame providing high mechanical strength and low vibration levels

Features

Standard

- Rated output: 0.25 HP to 75 HP
- Number of Poles: 2 to 8
- Frame size: 143T to 364/5T
- Frequency: 60 Hz
- Voltage: 208-230/460 V
- Brake power supply: 220-240 V
- Normally closed brake
- Design:
 - B (High Efficiency or NEMA Premium Efficiency)
 - A (Standard Efficiency or Super Premium Efficiency)
- Insulation class: F (DT 80K)
- Degree of protection: IP55
- Mounting: F1
- Cooling method: TEFC (Totally Enclosed Fan-Cooled) - IC411
- Frame and terminal box material: Cast iron FC-200
- Fan material:
 - Plastic (frames 143T to 215T)
 - Aluminum (frames 254T to 364/5T)
- Shaft material: AISI 1040/45
- Ball bearings
- Manual brake release (up to frame 326T)
- DE bearing seal:
 - V-ring (frames 143T to 326T)
 - WSeal® (frame 364/5T)
- NDE bearing: Lip seal
- Painting plan: 207A (frames 143T to 215T) and 203A (from frame 254T up), classified as corrosion category C2, according to ISO 12944:2

Optional

- Mounting: F2, F3 flanges, footless, vertical
- Degree of Protection: IP56, IP65, IP66
- Frequency: 50Hz
- Voltage: 575 V and others
- DE bearing seal: W3 Seal, taconite seal, INPRO/SEAL®
- Vibration level: Degree B (according to NEMA MG-1)
- Winding thermal protection: thermostat or thermistor
- Space heater
- Cable gland
- Drip cover
- Tropicalized internal painting
- Encoder
- Stainless steel screws
- Cooling method: TEBC – Totally enclosed blower cooled (IC 416)
- Insulation class: “H”
- Able to operate with variable frequency Inverter*
- Microswitch to monitor the air gap or brake opening (from frame 182T up)
- Brake power supply:
 - 380-415 V
 - 440-480 V
 - 525-575 V
- Additional terminal box for frames 254T to 364/5T

**For motors able to operate with variable frequency Inverter, WEG recommends the use of thermal protection on the winding.*



Optimizations of the braking system

New brake

- The friction element of the new brake provides less wear and more safety
- “Interchangeable with other global brands”
- Guarantee of fast and accurate stops
- System with fewer moving parts reduces downtime for maintenance

Manual release lever

- Motor shaft may remain free in emergency situations or when necessary

Standard torques

- The torques are established by frame so as to provide shorter braking times

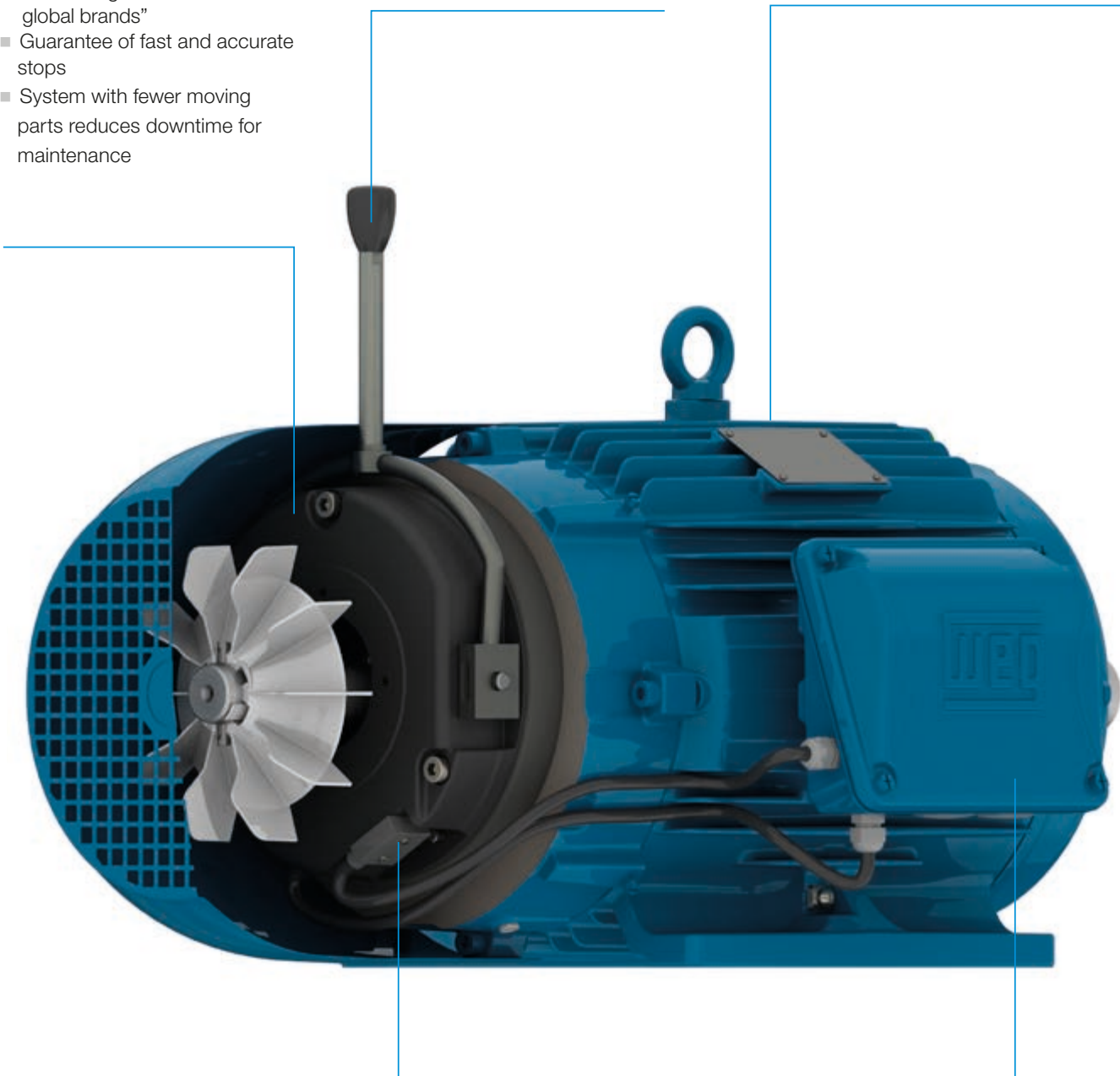

Microswitch (optional)

- Sensor to monitor the opening (I/O) or wear of the brake
- It indicates when to replace the friction disc, eliminating the need of manual monitoring

Rectifier

- It can operate with voltage variations of up to 10%
- Robust and compact construction that allows installation in the motor main terminal box

General features

Ideal for applications that require immediate, accurate and safe stops, position control and energy saving. The W22 brake motor is suitable for many different applications, such as load elevators, hoists, shears, machining equipment, looms, packaging machines, conveyors, washing and bottling machines, bending machines, among others.

How does a brake work?

In order to ensure fast and accurate stops, the system of the W22 brake motor works as follows: when the motor is disconnected from the line, the current of the brake coil is also interrupted, which makes the coil stop actuating. Then, the springs push the armature towards the motor, compressing the brake disc between the armature and the ND-endshield, thus braking the motor.

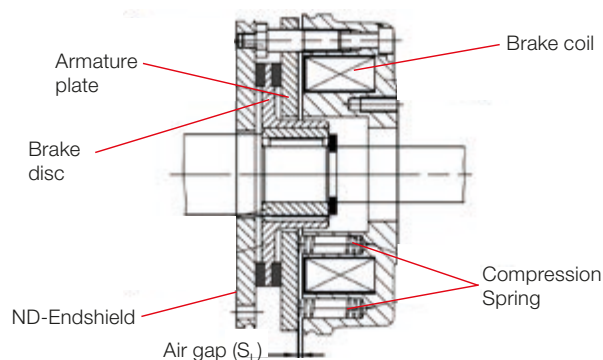

Figure 1 - Scheme of the brake components.

When Power is applied, the system simultaneously starts the motor and powers up the brake coil. The armature is attracted against the frame of the brake coil, overcoming the pressure of the springs and releasing the brake disc, which moves in the axial direction away from the friction surface. Thus, the braking action ceases and the motor is free to start.

Electromagnet coil power supply

The electromagnet coil is powered by direct current (DC) which can be supplied by a DC voltage source or bridge rectifier which converts AC to DC current. The bridge rectifier consists of diodes and varistors that filter undesirable voltage spikes and enable fast current shutdown. The direct current power supply provides higher speed and reliable brake operation.

The alternating current (AC) power supply for the bridge rectifier can be obtained from an independent source, or from the motor terminals, provided the motor is not supplied by frequency inverter. This power supply can be 220/230/240 V, 380/400/415 V, or 440/460/480 V, according to the features of the bridge rectifier/brake coil assembly. The electromagnetic coil can be operated continuously within $\pm 10\%$ of its rated voltage.

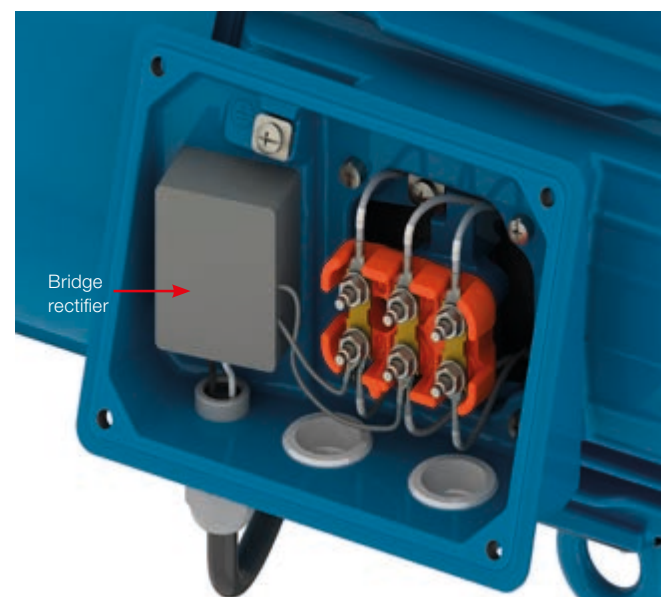

Figure 2 - Detail of the bridge rectifier inside the terminal box.

If the brake coil is supplied by direct current, it must be directly connected to the brake terminals.



Braking system

The W22 brake motor allows two braking system: normal braking or fast braking.

Normal braking

The bridge rectifier of the brake coil can be supplied directly from the motor terminals, without interruption, as shown in Figure 3.

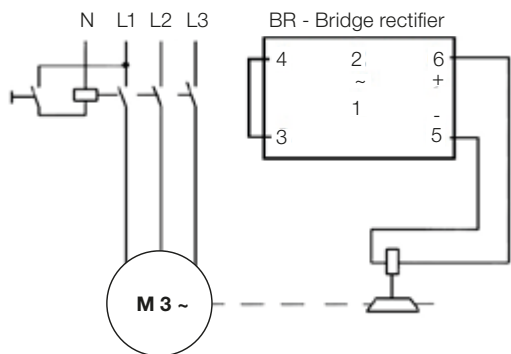

Figure 3 - Connection diagram of the bridge rectifier for normal braking.

Fast braking

For fast braking, the bridge rectifier must be connected as shown in Figure 4.

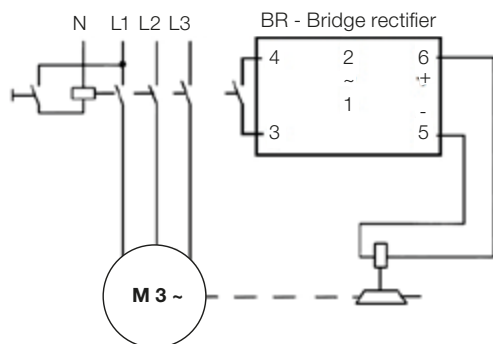

Figure 4 - Connection diagram of the bridge rectifier for fast braking.

Air gap adjustment

In order to ensure proper operation of the brake, it is important to check and adjust the air gap (space between brake armature and frame), according to the values of Table 1.

Frame	Brake size	Air gap ^{+0.1} / _{-0.05} [mm]
143/5	10	0.2
182/4	14	0.3
213/5	16	
254/6	18	0.4
284/6	20	
324/6 - 364/5	25	0.5

Table 1 - Values to adjust the air gap.

Power and resistance of the brake stator

Frame	Brake size	Brake voltage [V]	Electric power [W]	Resistance [ohm]
143/5	10	180	32	1,013
		205	33	1,273
182/4	14	180	53	611.3
		205		792.9
213/5	16	180	55	589.1
		205	56	750.5
254/6	18	180	85	387.2
		205		494.4
284/6	20	180	100	324
		205		420.3
324/6 364/5	25	180	110	294.6
		205		382.1

Table 2 - Power and resistance of the brake stator.

Optional accessories

In order to ensure even more safety and convenience for the application, the W22 brake motors can be supplied with some special features:

Manual release lever

It allows the motor shaft to be released in emergency cases or power outages. It can be supplied for motors up to frame 326T.

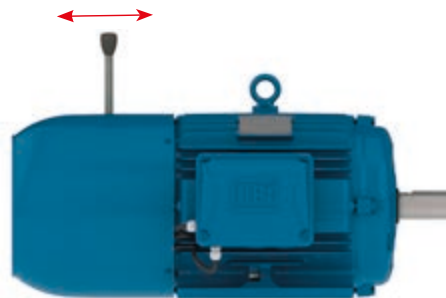

Figure 5 - Detail of the manual release lever.

Note: Under normal operating conditions, the lever cannot be activated.

Microswitch

From frame 182T up, the motors can be supplied with a monitoring sensor of the opening (I/O) or wear of the brake.

- Monitoring of the opening: ensures that the motor will not start if the brake is actuated (it prevents motor starts with the shaft locked);
- Monitoring of the wear: indicates the right moment to adjust or replace the brake lining.

How to choose a W22 brake motor

The W22 brake motor is a motor for quite specific applications that demand high safety and accuracy. Therefore, it is extremely important to take into account some criteria when choosing such equipment.

Basic data to make the best choice:

Determine the motor and the brake: the first step is to define the environment in which the equipment will be used so as to select the motor with the best electromechanical characteristics for the application. The type of brake must also be checked, informing the power supply and the required braking torque.

Define the ambient temperature: taking into account the ambient temperature at which the motor will operate, we can determine the minimum ideal cooling system for the brake operation, according to table 3.

Ambient temperature	Minimum cooling system of the motor
Up to 40°C	No ventilation / W-Easy Maintenance
Up to 50°C	Self-Ventilated / Air Over
Up to 60°C	Blower cooled
Up to 70°C	Blower cooled*

Table 3 - Definition of the cooling system according to the motor ambient temperature.

* For this condition, please contact WEG.

For other cooling system configurations, contact WEG.

Specify the degree of protection: the enclosures of electrical equipment, according to the characteristics and access conditions of the installation environment, must offer a certain degree of protection. Thus, equipment to be installed in a place subject to water jets, for example, must have an enclosure capable of withstanding such jets under certain pressures and angles of incidence without water ingress. Table 4 indicates the minimum cooling system necessary to ensure the degree of protection.

Degree of protection	Minimum cooling system of the motor
IP55	<ul style="list-style-type: none"> ■ No ventilation / Air Over (with fan cover) ■ Self-ventilated ■ With or without release lever
IP56/IP65/IP66	<ul style="list-style-type: none"> ■ Self-ventilated with brake protection cover ■ Without release lever
	<ul style="list-style-type: none"> ■ W-Easy Maintenance ■ With or without release lever

Table 4 - Degrees of protection and minimum cooling systems of the motor.

For other configurations, contact WEG.

Define the braking torque. The W22 brake motor line offers up to two torques per frame:

- Rated torque: standard torque supplied;
- Optional torque: used in load lifting applications, or where, due to the high load torque and/or inertia of the system, it is necessary the use of greater braking torques.

Available braking torques (Mk). The braking torque must be equal to or greater than the motor rated torque. Table 5 contains the main characteristics of the brakes, using the speed of 100 rpm as reference.

Frame	Torque at 100 rpm [ft.lb]		Maximum working speed [rpm]	Maximum dissipated energy Q _e [J]	Brake response time t ₁₂ [s]
	Rated torque	Optional torque			
143/5	11.8	17.0	4,000	12,000	0.020
182/4	44.2	-	3,600	30,000	0.030
213/5	59.0	92.2	3,600	36,000	
254/6	110.6	173.3	3,600	60,000	0.043
284/6	191.8	254.5	3,600	80,000	0.100
324/6	295.0	390.9	3,000	120,000	0.120
364/5	390.9	-			0.135

Table 5 - Characteristics of the brake according to the size and torque at 100 rpm.



Safety factor (k): For regular applications, WEG recommends the use of the safety factor “k” of 1.5 to 2 times the torque value. For special applications, such as lifting, it is recommended a safety factor “k” of 2 to 3 times the rated torque.

Check the brake power supply: The W22 brake motor can be supplied with full, half wave or special bridge rectifiers, as shown in Table 6.

Rated voltage V _{RMS} [Vca]	Brake size	Brake coil voltage [Vcc]	Wave form
110	6 to 25	103	Full
220-240		205	
380-415		180	Half wave
440-480		205	
525-575		250	

Tabela 6 - Bridge rectifier types.

Calculations for special applications

Calculation of the required torque for load lifting. For vertical applications, the braking torque must be obtained by means of the required torque calculation (M_{req}), which is given by the following expression:

$$M_{req} = k * \left(\frac{J_L * \Delta n \omega}{9.55 * \left(\frac{t_3 - t_{12}}{2} \right)} + M_L \right)$$

Where:

- M_{req} : required torque [Nm];
- “k”: safety factor that must be added due to the uncertainties of the speed at the brake, maximum torque, maximum load inertia, among other variables.
- J_L : total inertia on the rotor shaft = load inertia + system inertia + motor inertia [kgm²];
- $\Delta n \omega$: speed [rpm];
- t_3 : required braking time [s];
- t_{12} : brake response time [s].

Calculation of the required torque for application in translational motion of overhead cranes. For horizontal applications, the braking torque must also be obtained by means of the required torque calculation (M_{req}), which is given by the following expression:

$$M_{req} = \left(\frac{k * J_L * \Delta n \omega}{9.55 * \left(\frac{t_3 - t_{12}}{2} \right)} \right)$$

Correction of the torque due to the speed at the moment of the brake (M_R): in cases of emergency stops (at working speed) or in motors without frequency inverter, the motor rated speed is considered the braking speed. Thus, the braking torque must be corrected as indicated in Table 7.

Frames	Brake size	Torque correction at speed (rpm) [%]							
		750	900	1000	1200	1500	1800	3000	3600
143 - 145	10	91.5	89.5	88.2	86	83	81	76	74.7
182 - 184	14	90	87.5	86	83.5	80	77.7	73	71.5
213 - 215	16	89.5	87	85.5	82.5	79	76.5	72	70.2
254 - 256	18	88	85.7	84	80.7	77	74.5	70	68
284 - 286	20	87	84.5	82.5	79	75	72.2	68	66.2
324 - 365	25	86	83	81	77.5	73	70.1	66	-

Table 7 - Torque correction.

For brakes with frequency inverter, it is necessary to know the speed at which the brake will be performed, and the braking torque must be corrected if necessary.

$$M_R = \frac{M_{req} * 100}{\text{correction (\%)}}$$

Finally, it must be checked if the corrected required torque is equal to or smaller than the torque of the selected brake. If it is bigger, it will be necessary to increase the torque of the brake.

$$M_K \geq M_R$$

Check the cooling of the brake: after selecting the brake, it is necessary to check if the cooling will meet the start duty cycle of the application. The cooling can be obtained through the following equation:

$$Q = \frac{J_L * \Delta n \omega^2}{182.5} * \frac{M_K}{M_K - M_L}$$

Where:

- Q: dissipated heat [J];
- M_K : brake torque [Nm];
- M_L : load torque [Nm].

With the result found, the value of “Q” must be positioned on the axis of ordinates and the number of starts per hour on the axis of abscissa, and then we should observe if the point is below the curve of the selected brake. If it is below the curve, it indicates that the brake is thermally able to brake the load. Otherwise, the size of the brake must be increased so as to improve the cooling.

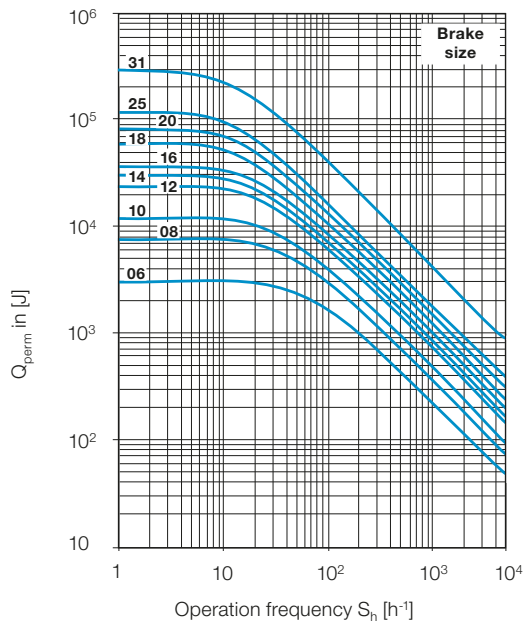

Figure 6 – Cooling curve (Q) according to starts per hour.

Brake power supply. When the brake coil is powered by a bridge rectifier, the rectifier input terminals must be supplied with AC voltage. The relations between the motor voltage, the type of bridge rectifier and the brake coil power supply must be in accordance with table 8.

Motor power supply (connection) [VAC]	Power supply of the brake bridge rectifier [VAC]	Brake type		Supply of the bridge rectifier through the motor electrical connections (IEC-NBR / NEMA)				
		Normal	Fast	Terminal 1 (**)	Terminal 2 (**)			
					3-wire motor	6-wire motor	9-wire motor	12-wire motor
220/230/240 (T)	220/230/240	Figure 3	Figure 4	U1 / T1	W1 / T3	W1 / T3	W1 / T3	W1 / T3
380/400/415 (Y)					NA	W2 / T6	NA	W4 / T12
380/400/415 (T)	W1 / T3				W1 / T3	W1 / T3	W1 / T3	
440/460 (Y)	NA				NA	NA	NA	
440/460 (T)	W1 / T3				W1 / T3	W1 / T3	W1 / T3	
525/550/575 (Y)	NA				NA	NA	NA	
525/550/575 (T)	W1 / T3				W1 / T3	W1 / T3	W1 / T3	

Table 8 - Power supply of the bridge rectifier through the motor terminals.

T = Delta connection Y = Star connection NA = Not available

* The bridge rectifier can be directly supplied by the motor cables or independently, at the customer's discretion.

** Terminal markings are only valid for single speed motors.

Note: besides the previous options, the electromagnetic brake with 24-Vdc coil is also available. In this case, only the brake is included (bridge rectifier not supplied) and the brake coil must be powered by an independent source.





Performance Data

W22 Brake Motor - Standard Efficiency

Output		Frame	Full Load Torque (ft.lb)	Locked Rotor Current		Locked Rotor Torque Tl/Tn	Break-down Torque Tb/Tn	Inertia J (lb*ft ²)	Allowable locked rotor time (s)		Weight (lb)	Sound dB(A)	Service Factor	460 V						Full load current In (A)	
				Code	II/In				Hot	Cold				Rated speed (rpm)	% of full load			Power Factor			
															50	75	100	50	75		100
X Pole																					
0.25	0.18	143T	0.270	K	2.9	2.0	2.3	0.0038	25	55	19.5	44.0	1.15	675	40.0	47.0	51.0	0.37	0.45	0.50	1.85
0.33	0.25	143T	0.350	J	3.1	2.3	2.5	0.0044	19	42	21.5	44.0	1.15	680	41.0	49.0	55.0	0.42	0.46	0.54	2.21
0.5	0.37	143/5T	0.530	L	3.5	2.2	2.5	0.0055	16	35	24.5	44.0	1.15	680	41.0	49.0	53.0	0.38	0.42	0.50	3.46
1	0.75	182/4T	1.03	L	4.3	2.7	3.0	0.0147	10	22	50.0	47.0	1.15	695	58.0	66.0	69.0	0.34	0.43	0.50	5.71
1.5	1.1	213T	1.56	K	5.4	1.9	2.1	0.0445	27	59	69.0	47.0	1.15	690	68.0	73.0	75.0	0.42	0.54	0.63	6.11
2	1.5	213/5T	2.08	K	5.3	1.9	2.5	0.0542	24	53	74.0	47.0	1.15	690	70.0	74.0	76.0	0.44	0.56	0.64	8.09
3	2.2	213/5T	3.09	L	6.1	2.3	3.0	0.0742	14	31	84.0	47.0	1.15	695	68.0	73.0	77.0	0.45	0.56	0.64	11.7
4	3	254T	4.12	J	5.5	2.0	2.5	0.1237	20	44	104	51.0	1.15	695	79.0	80.0	80.0	0.50	0.64	0.71	13.9
5	3.7	254/6T	5.19	J	5.7	2.2	2.5	0.1499	15	33	124	51.0	1.15	690	78.0	81.0	81.0	0.53	0.64	0.71	16.9
6	4.5	284T	6.09	J	6.2	2.1	2.6	0.2177	23	51	179	57.0	1.15	705	84.1	86.4	86.5	0.55	0.66	0.73	18.7
7.5	5.5	284/6T	7.62	J	6.3	2.3	2.7	0.2313	19	42	194	57.0	1.15	705	83.3	85.7	85.9	0.52	0.64	0.72	23.4
10	7.5	284/6T	10.2	J	6.3	2.5	2.6	0.2585	15	33	209	57.0	1.15	705	83.0	85.4	85.5	0.52	0.64	0.71	32.4
12.5	9.2	324/6T	12.7	H	6.0	1.9	2.4	0.4059	24	53	276	63.0	1.15	705	86.0	88.0	88.5	0.53	0.64	0.71	38.4
20	15	364/5T	20.3	J	6.5	1.7	2.5	0.6537	21	46	395	60.0	1.15	705	88.4	90.1	88.3	0.60	0.71	0.76	58.6
High-Output Design																					
10	7.5	286T	10.2	J	6.3	2.5	2.6	0.2585	15	33	209	57.0	1.15	705	83.0	85.4	85.5	0.52	0.64	0.71	32.4
12.5	9.2	326T	12.7	H	6.0	1.9	2.4	0.4059	24	53	276	63.0	1.15	705	86.0	88.0	88.5	0.53	0.64	0.71	38.4
XII Pole																					
3	2.2	254T	26.6	H	3.7	2.3	2.4	2.73	65	143	267	51.0	1.15	585	70.0	75.0	78.0	0.35	0.45	0.52	14.2
4	3	254/6T	35.4	G	3.6	1.9	2.1	3.14	65	143	311	51.0	1.15	585	72.0	76.0	80.0	0.38	0.48	0.55	17.9
5	3.7	284T	44.3	K	5.7	2.3	2.8	5.81	40	88	408	57.0	1.15	585	75.0	78.0	81.0	0.46	0.57	0.64	18.7
6	4.5	284/6T	53.6	K	5.7	2.3	2.7	6.13	35	77	432	57.0	1.15	580	78.0	80.0	82.0	0.45	0.57	0.65	22.2
7.5	5.5	284/6T	66.4	L	6.4	2.3	2.7	6.46	20	44	454	57.0	1.15	585	78.0	80.0	82.0	0.41	0.53	0.61	28.9
10	7.5	324/6T	88.6	K	6.0	1.9	2.7	8.81	22	48	809	63.0	1.15	585	76.0	81.0	83.0	0.45	0.60	0.65	36.5
12.5	9.2	364/5T	110	J	6.0	1.7	2.7	15.1	34	75	849	60.0	1.15	590	84.0	86.0	88.0	0.45	0.58	0.66	41.6
15	11	364/5T	132	J	6.0	1.7	2.6	16.3	29	64	915	60.0	1.15	590	84.0	86.0	88.0	0.47	0.59	0.67	49.0
High-Output Design																					
10	7.5	326T	88.6	K	6.0	1.9	2.7	8.81	22	48	809	63.0	1.15	585	76.0	81.0	83.0	0.45	0.60	0.65	36.5
20	15	364/5T	177	J	6.0	1.5	2.3	21.2	27	59	1091	60.0	1.15	585	85.0	87.0	88.0	0.50	0.62	0.69	64.8

W22 Brake Motor - High Efficiency

Output		Frame	Full Load Torque (ft.lb)	Locked Rotor Current		Locked Rotor Torque Tl/Tn	Break-down Torque Tb/Tn	Inertia J (lb*ft²)	Allowable locked rotor time (s)		Weight (lb)	Sound dB(A)	Service Factor	460 V						Full load current In (A)	
				Code	I/In				Rated speed (rpm)	% of full load				Power Factor							
										50				75	100	50	75	100			
HP	kW							Hot	Cold												
II Pole																					
1	0.75	143/5T	1.49	K	7.0	2.3	2.8	0.0278	13	29	37.5	68.0	1.25	3480	72.0	75.5	75.5	0.69	0.79	0.84	1.48
1.5	1.1	143/5T	2.25	J	6.8	2.5	3.0	0.0370	13	29	41.9	68.0	1.25	3455	78.5	82.5	82.5	0.68	0.78	0.84	1.99
2	1.5	143/5T	3.00	J	7.4	2.5	3.0	0.0427	16	35	45.2	68.0	1.25	3450	81.5	84.0	84.0	0.69	0.80	0.85	2.64
3	2.2	182/4T	4.44	H	7.2	2.0	3.1	0.1644	28	62	98.1	69.0	1.25	3500	82.5	85.5	85.5	0.76	0.84	0.88	3.67
5	3.7	182/4T	7.42	H	7.3	2.0	3.0	0.1906	27	59	101	69.0	1.25	3490	85.5	87.5	87.5	0.78	0.86	0.89	5.90
7.5	5.5	213/5T	11.1	H	6.7	2.1	3.0	0.3842	18	40	148	72.0	1.25	3510	87.5	88.5	88.5	0.75	0.84	0.88	8.86
10	7.5	213/5T	14.8	G	6.6	2.0	2.7	0.4680	19	42	163	72.0	1.25	3510	88.5	89.5	89.5	0.79	0.87	0.90	11.8
15	11	254/6T	22.1	G	6.2	2.0	2.5	1.26	18	40	267	72.0	1.25	3520	89.5	90.2	90.2	0.78	0.86	0.88	17.4
20	15	254/6T	29.4	G	6.0	2.0	2.5	1.54	15	33	306	72.0	1.25	3520	90.2	90.2	90.2	0.78	0.85	0.88	23.7
25	18.5	284/6T	36.7	F	6.0	2.0	2.4	2.29	15	33	408	72.0	1.25	3530	91.0	91.0	91.0	0.83	0.88	0.90	29.0
30	22	284/6T	44.0	F	6.0	2.0	2.4	2.83	14	31	439	72.0	1.25	3530	91.0	91.0	91.0	0.82	0.88	0.90	33.7
40	30	284/6T	58.7	G	6.2	2.1	2.5	2.83	10	22	474	72.0	1.15	3530	91.7	91.7	91.7	0.82	0.88	0.90	45.6
High-Output Design																					
1	0.75	143T	1.49	K	7.0	2.3	2.8	0.0278	13	29	37.5	68.0	1.25	3480	72.0	75.5	75.5	0.69	0.79	0.84	1.48
1	0.75	145T	1.49	K	7.0	2.3	2.8	0.0278	13	29	37.5	68.0	1.25	3480	72.0	75.5	75.5	0.69	0.79	0.84	1.48
1.5	1.1	143T	2.25	J	6.8	2.5	3.0	0.0370	13	29	41.9	68.0	1.25	3455	78.5	82.5	82.5	0.68	0.78	0.84	1.99
1.5	1.1	145T	2.25	J	6.8	2.5	3.0	0.0370	13	29	41.9	68.0	1.25	3455	78.5	82.5	82.5	0.68	0.78	0.84	1.99
2	1.5	145T	3.00	J	7.4	2.5	3.0	0.0427	16	35	45.2	68.0	1.25	3450	81.5	84.0	84.0	0.69	0.80	0.85	2.64
2	1.5	182T	2.96	J	7.0	2.0	3.1	0.1471	55	121	94.8	69.0	1.25	3500	78.5	82.5	84.0	0.74	0.82	0.87	2.58
2	1.5	182/4T	2.96	J	7.0	2.0	3.1	0.1471	55	121	94.8	69.0	1.25	3500	78.5	82.5	84.0	0.74	0.82	0.87	2.58
3	2.2	143/5T	4.51	H	6.9	2.8	3.1	0.0610	11	24	55.1	68.0	1.15	3450	85.5	85.5	85.5	0.71	0.81	0.86	3.76
3	2.2	145T	4.51	H	6.9	2.8	3.1	0.0610	11	24	55.1	68.0	1.15	3450	85.5	85.5	85.5	0.71	0.81	0.86	3.76
3	2.2	182T	4.44	H	7.2	2.0	3.1	0.1644	28	62	98.1	69.0	1.25	3500	82.5	85.5	85.5	0.76	0.84	0.88	3.67
3	2.2	184T	4.44	H	7.2	2.0	3.1	0.1644	28	62	98.1	69.0	1.25	3500	82.5	85.5	85.5	0.76	0.84	0.88	3.67
5	3.7	184T	7.42	H	7.3	2.0	3.0	0.1906	27	59	101	69.0	1.25	3490	85.5	87.5	87.5	0.78	0.86	0.89	5.90
7.5	5.5	182/4T	11.2	H	7.2	2.2	2.9	0.2288	16	35	106	69.0	1.15	3470	87.5	88.5	88.5	0.83	0.88	0.90	8.48
7.5	5.5	184T	11.2	H	7.2	2.2	2.9	0.2288	16	35	106	69.0	1.15	3470	87.5	88.5	88.5	0.83	0.88	0.90	8.48
7.5	5.5	213T	11.1	H	6.7	2.1	3.0	0.3842	18	40	148	72.0	1.25	3510	87.5	88.5	88.5	0.75	0.84	0.88	8.86
7.5	5.5	215T	11.1	H	6.7	2.1	3.0	0.3842	18	40	148	72.0	1.25	3510	87.5	88.5	88.5	0.75	0.84	0.88	8.86
10	7.5	215T	14.8	G	6.6	2.0	2.7	0.4680	19	42	163	72.0	1.25	3510	88.5	89.5	89.5	0.79	0.87	0.90	11.8
15	11	213/5T	22.3	G	6.3	2.1	2.5	0.6402	15	33	183	72.0	1.15	3490	89.5	90.2	90.2	0.84	0.89	0.91	16.8
15	11	215T	22.3	G	6.3	2.1	2.5	0.6402	15	33	183	72.0	1.15	3490	89.5	90.2	90.2	0.84	0.89	0.91	16.8
15	11	254T	22.1	G	6.2	2.0	2.5	1.26	18	40	267	72.0	1.25	3520	89.5	90.2	90.2	0.78	0.86	0.88	17.4
15	11	256T	22.1	G	6.2	2.0	2.5	1.26	18	40	267	72.0	1.25	3520	89.5	90.2	90.2	0.78	0.86	0.88	17.4
20	15	254T	29.4	G	6.0	2.0	2.5	1.54	15	33	306	72.0	1.25	3520	90.2	90.2	90.2	0.78	0.85	0.88	23.7
20	15	256T	29.4	G	6.0	2.0	2.5	1.54	15	33	306	72.0	1.25	3520	90.2	90.2	90.2	0.78	0.85	0.88	23.7
25	18.5	254/6T	36.8	G	6.2	2.0	2.3	1.54	11	24	315	72.0	1.15	3515	91.0	91.0	91.0	0.81	0.87	0.90	28.4
25	18.5	256T	36.8	G	6.2	2.0	2.3	1.54	11	24	315	72.0	1.15	3515	91.0	91.0	91.0	0.81	0.87	0.90	28.4
25	18.5	284TS	36.7	F	6.0	2.0	2.4	2.29	15	33	408	72.0	1.25	3530	91.0	91.0	91.0	0.83	0.88	0.90	29.0
25	18.5	286TS	36.7	F	6.0	2.0	2.4	2.29	15	33	408	72.0	1.25	3530	91.0	91.0	91.0	0.83	0.88	0.90	29.0
30	22	284TS	44.0	F	6.0	2.0	2.4	2.83	14	31	439	72.0	1.25	3530	91.0	91.0	91.0	0.82	0.88	0.90	33.7
30	22	286TS	44.0	F	6.0	2.0	2.4	2.83	14	31	439	72.0	1.25	3530	91.0	91.0	91.0	0.82	0.88	0.90	33.7
40	30	284TS	58.7	G	6.2	2.1	2.5	2.83	10	22	474	72.0	1.15	3530	91.7	91.7	91.7	0.82	0.88	0.90	45.6
40	30	286TS	58.7	G	6.2	2.1	2.5	2.83	10	22	474	72.0	1.15	3530	91.7	91.7	91.7	0.82	0.88	0.90	45.6

Performance Data

W22 Brake Motor - High Efficiency

Output HP	kW	Frame	Full Load Torque (ft.lb)	Locked Rotor Current		Locked Rotor Torque Tl/Tn	Break-down Torque Tb/Tn	Inertia J (lb*ft ²)	Allowable locked rotor time (s)		Weight (lb)	Sound dB(A)	Service Factor	460 V						Full load current In (A)	
				Code	II/In				Hot	Cold				Rated speed (rpm)	% of full load			Power Factor			
															50	75	100	50	75		100
IV Pole																					
1	0.75	143/5T	2.93	M	8.5	2.8	3.5	0.0911	13	29	40.8	51.0	1.25	1770	78.5	82.5	82.5	0.48	0.60	0.69	1.65
1.5	1.1	143/5T	4.42	M	9.0	2.5	3.0	0.1172	14	31	44.1	51.0	1.25	1760	80.0	82.5	84.0	0.57	0.70	0.78	2.11
2	1.5	143/5T	5.90	J	7.0	2.4	2.8	0.1296	11	24	46.3	51.0	1.25	1755	82.5	84.0	84.0	0.59	0.71	0.80	2.80
3	2.2	182/4T	8.83	K	7.5	2.2	2.8	0.2636	18	40	97.0	56.0	1.25	1760	86.5	87.5	87.5	0.61	0.72	0.78	4.05
5	3.7	182/4T	14.8	J	6.8	1.9	2.6	0.3683	14	31	106	56.0	1.25	1750	86.5	87.5	87.5	0.60	0.72	0.80	6.63
7.5	5.5	213/5T	22.1	H	6.5	2.1	2.6	0.9800	13	29	159	58.0	1.25	1755	88.5	89.5	89.5	0.66	0.77	0.83	9.31
10	7.5	213/5T	29.5	H	6.5	2.0	2.5	1.16	12	26	174	58.0	1.25	1755	89.5	89.5	89.5	0.68	0.80	0.84	12.5
15	11	254/6T	44.0	G	6.0	2.3	2.6	2.38	15	33	269	64.0	1.25	1765	90.2	91.0	91.0	0.68	0.80	0.84	17.8
20	15	254/6T	58.9	G	6.0	2.0	2.4	2.86	14	31	304	64.0	1.25	1760	90.2	91.0	91.0	0.72	0.81	0.85	24.3
25	18.5	284/6T	73.6	F	6.0	2.2	2.4	5.11	23	51	452	64.0	1.25	1760	91.7	92.4	92.4	0.73	0.82	0.86	29.2
30	22	284/6T	88.3	F	6.0	2.3	2.4	5.32	19	42	483	64.0	1.25	1760	92.4	93.0	92.4	0.74	0.83	0.87	34.3
40	30	324/6T	117	G	6.0	2.1	2.4	7.85	18	40	553	69.0	1.25	1770	92.4	93.0	93.0	0.74	0.82	0.85	47.6
50	37	324/6T	146	F	6.0	2.2	2.4	9.16	15	33	602	69.0	1.25	1770	93.0	93.6	93.0	0.74	0.82	0.86	58.1
60	45	364/5T	176	G	6.3	2.0	2.3	17.4	12	26	900	70.0	1.25	1770	93.6	93.6	93.6	0.79	0.85	0.87	69.4
60	45	364/5TS	176	G	6.3	2.0	2.3	17.4	12	26	900	70.0	1.25	1770	93.6	93.6	93.6	0.79	0.85	0.87	69.4
75	55	364/5T	220	G	6.3	2.1	2.4	19.9	10	22	946	70.0	1.25	1770	94.1	94.1	94.1	0.79	0.85	0.87	84.3
75	55	364/5TS	220	G	6.3	2.1	2.4	19.9	10	22	946	70.0	1.25	1770	94.1	94.1	94.1	0.79	0.85	0.87	84.3
High-Output Design																					
1	0.75	143T	2.93	M	8.5	2.8	3.5	0.0911	13	29	40.8	51.0	1.25	1770	78.5	82.5	82.5	0.48	0.60	0.69	1.65
1	0.75	145T	2.93	M	8.5	2.8	3.5	0.0911	13	29	40.8	51.0	1.25	1770	78.5	82.5	82.5	0.48	0.60	0.69	1.65
1.5	1.1	145T	4.42	M	9.0	2.5	3.0	0.1172	14	31	44.1	51.0	1.25	1760	80.0	82.5	84.0	0.57	0.70	0.78	2.11
2	1.5	145T	5.90	J	7.0	2.4	2.8	0.1296	11	24	46.3	51.0	1.25	1755	82.5	84.0	84.0	0.59	0.71	0.80	2.80
3	2.2	182T	8.83	K	7.5	2.2	2.8	0.2636	18	40	97.0	56.0	1.25	1760	86.5	87.5	87.5	0.61	0.72	0.78	4.05
3	2.2	184T	8.83	K	7.5	2.2	2.8	0.2636	18	40	97.0	56.0	1.25	1760	86.5	87.5	87.5	0.61	0.72	0.78	4.05
5	3.7	184T	14.8	J	6.8	1.9	2.6	0.3683	14	31	106	56.0	1.25	1750	86.5	87.5	87.5	0.60	0.72	0.80	6.63
5	3.7	213T	14.8	H	6.4	2.0	2.5	0.8061	20	44	152	58.0	1.25	1755	86.5	87.5	87.5	0.68	0.79	0.84	6.32
5	3.7	213/5T	14.8	H	6.4	2.0	2.5	0.8061	20	44	152	58.0	1.25	1755	86.5	87.5	87.5	0.68	0.79	0.84	6.32
5	3.7	215T	14.8	H	6.4	2.0	2.5	0.8061	20	44	152	58.0	1.25	1755	86.5	87.5	87.5	0.68	0.79	0.84	6.32
7.5	5.5	213T	22.1	H	6.5	2.1	2.6	0.9800	13	29	159	58.0	1.25	1755	88.5	89.5	89.5	0.66	0.77	0.83	9.31
7.5	5.5	215T	22.1	H	6.5	2.1	2.6	0.9800	13	29	159	58.0	1.25	1755	88.5	89.5	89.5	0.66	0.77	0.83	9.31
10	7.5	215T	29.5	H	6.5	2.0	2.5	1.16	12	26	174	58.0	1.25	1755	89.5	89.5	89.5	0.68	0.80	0.84	12.5
10	7.5	254T	29.4	G	6.0	2.1	2.4	1.91	20	44	247	64.0	1.25	1765	88.5	89.5	89.5	0.70	0.80	0.84	12.5
10	7.5	254/6T	29.4	G	6.0	2.1	2.4	1.91	20	44	247	64.0	1.25	1765	88.5	89.5	89.5	0.70	0.80	0.84	12.5
10	7.5	256T	29.4	G	6.0	2.1	2.4	1.91	20	44	247	64.0	1.25	1765	88.5	89.5	89.5	0.70	0.80	0.84	12.5
15	11	254T	44.0	G	6.0	2.3	2.6	2.38	15	33	269	64.0	1.25	1765	90.2	91.0	91.0	0.68	0.80	0.84	17.8
15	11	256T	44.0	G	6.0	2.3	2.6	2.38	15	33	269	64.0	1.25	1765	90.2	91.0	91.0	0.68	0.80	0.84	17.8
20	15	256T	58.9	G	6.0	2.0	2.4	2.86	14	31	304	64.0	1.25	1760	90.2	91.0	91.0	0.72	0.81	0.85	24.3
20	15	284T	58.9	G	6.0	2.0	2.3	5.11	27	59	408	64.0	1.25	1760	91.0	91.0	91.0	0.74	0.82	0.86	24.1
20	15	284TS	58.9	G	6.0	2.0	2.3	5.11	27	59	408	64.0	1.25	1760	91.0	91.0	91.0	0.74	0.82	0.86	24.1
20	15	284/6T	58.9	G	6.0	2.0	2.3	5.11	27	59	408	64.0	1.25	1760	91.0	91.0	91.0	0.74	0.82	0.86	24.1
25	18.5	284T	73.6	F	6.0	2.2	2.4	5.11	23	51	452	64.0	1.25	1760	91.7	92.4	92.4	0.73	0.82	0.86	29.2
25	18.5	284TS	73.6	F	6.0	2.2	2.4	5.11	23	51	452	64.0	1.25	1760	91.7	92.4	92.4	0.73	0.82	0.86	29.2
25	18.5	286T	73.6	F	6.0	2.2	2.4	5.11	23	51	452	64.0	1.25	1760	91.7	92.4	92.4	0.73	0.82	0.86	29.2
25	18.5	284/6TS	73.6	F	6.0	2.2	2.4	5.11	23	51	452	64.0	1.25	1760	91.7	92.4	92.4	0.73	0.82	0.86	29.2
30	22	286T	88.3	F	6.0	2.3	2.4	5.32	19	42	483	64.0	1.25	1760	92.4	93.0	92.4	0.74	0.83	0.87	34.3
30	22	284/6TS	88.3	F	6.0	2.3	2.4	5.32	19	42	483	64.0	1.25	1760	92.4	93.0	92.4	0.74	0.83	0.87	34.3
40	30	324T	117	G	6.0	2.1	2.4	7.85	18	40	553	69.0	1.25	1770	92.4	93.0	93.0	0.74	0.82	0.85	47.6
40	30	324TS	117	G	6.0	2.1	2.4	7.85	18	40	553	69.0	1.25	1770	92.4	93.0	93.0	0.74	0.82	0.85	47.6
40	30	326T	117	G	6.0	2.1	2.4	7.85	18	40	553	69.0	1.25	1770	92.4	93.0	93.0	0.74	0.82	0.85	47.6
40	30	326TS	117	G	6.0	2.1	2.4	7.85	18	40	553	69.0	1.25	1770	92.4	93.0	93.0	0.74	0.82	0.85	47.6
50	37	326T	146	F	6.0	2.2	2.4	9.16	15	33	803	69.0	1.25	1770	93.0	93.6	93.0	0.74	0.82	0.86	58.1
50	37	326TS	146	F	6.0	2.2	2.4	9.16	15	33	803	69.0	1.25	1770	93.0	93.6	93.0	0.74	0.82	0.86	58.1
50	37	364/5T	146	F	6.0	1.9	2.2	17.4	15	33	853	70.0	1.25	1770	93.0	93.0	93.0	0.79	0.85	0.87	57.4
50	37	364/5TS	146	F	6.0	1.9	2.2	17.4	15	33	853	70.0	1.25	1770	93.0	93.0	93.0	0.79	0.85	0.87	57.4
60	45	326T	176	G	6.0	2.1	2.4	9.16	14	31	686	69.0	1.15	1770	93.0	93.6	93.6	0.73	0.81	0.85	71.0
60	45	324/6T	176	G	6.0	2.1	2.4	9.16	14	31	686	69.0	1.15	1770	93.0	93.6	93.6	0.73	0.81	0.85	71.0
60	45	324/6TS	176	G	6.0	2.1	2.4	9.16	14	31	686	69.0	1.15	1770	93.0	93.6	93.6	0.73	0.81	0.85	71.0

W22 Brake Motor - High Efficiency

Output		Frame	Full Load Torque (ft.lb)	Locked Rotor Current		Locked Rotor Torque Tl/Tn	Break-down Torque Tb/Tn	Inertia J (lb*ft²)	Allowable locked rotor time (s)		Weight (lb)	Sound dB(A)	Service Factor	460 V							
														Rated speed (rpm)	% of full load			Power Factor			Full load current In (A)
															50	75	100	50	75	100	
HP	kW	Code	II/In					Hot	Cold												
VI Pole																					
1	0.75	143/5T	4.51	J	5.7	2.5	2.8	0.1303	23	51	47.4	49.0	1.25	1150	75.5	80.0	80.0	0.50	0.63	0.72	1.63
1.5	1.1	182/4T	6.70	J	6.0	2.0	2.6	0.4786	55	121	81.6	52.0	1.25	1160	81.5	84.0	85.5	0.53	0.65	0.72	2.24
2	1.5	182/4T	8.93	J	6.0	2.1	2.6	0.5657	47	103	92.6	52.0	1.25	1160	84.0	86.5	86.5	0.54	0.66	0.73	2.98
3	2.2	213/5T	13.3	H	6.1	1.8	2.4	0.9933	76	167	130	55.0	1.25	1170	84.0	86.5	87.5	0.56	0.68	0.74	4.15
5	3.7	213/5T	22.2	J	6.4	2.1	2.3	1.47	35	77	182	55.0	1.25	1165	86.5	87.5	87.5	0.55	0.67	0.75	7.08
7.5	5.5	254/6T	33.1	G	6.1	2.0	2.7	2.56	23	51	269	59.0	1.25	1175	87.5	88.5	89.5	0.62	0.74	0.80	9.64
10	7.5	254/6T	44.3	G	6.0	2.0	2.6	2.90	20	44	293	59.0	1.25	1170	88.5	89.5	89.5	0.63	0.75	0.80	13.1
15	11	284/6T	66.1	G	6.0	2.2	2.5	7.20	17	37	408	59.0	1.25	1175	90.2	90.2	90.2	0.72	0.81	0.86	17.8
20	15	284/6T	88.2	G	6.1	2.1	2.4	8.18	16	35	454	59.0	1.25	1175	90.2	91.0	91.0	0.73	0.82	0.86	24.1
25	18.5	324/6T	110	F	5.7	2.0	2.4	10.2	19	42	538	62.0	1.25	1175	91.0	91.7	91.7	0.69	0.79	0.83	30.5
30	22	324/6T	132	F	5.8	2.0	2.4	11.9	18	40	582	62.0	1.25	1175	91.0	91.7	91.7	0.69	0.79	0.84	35.8
40	30	364/5T	176	G	6.2	1.9	2.3	23.5	16	35	869	66.0	1.25	1180	93.0	93.0	93.0	0.74	0.83	0.86	47.1
50	37	364/5T	220	G	6.2	1.9	2.3	29.0	15	33	915	66.0	1.25	1180	93.0	93.0	93.0	0.75	0.83	0.86	58.1
50	37	364/5TS	220	G	6.2	1.9	2.3	29.0	15	33	915	66.0	1.25	1180	93.0	93.0	93.0	0.75	0.83	0.86	58.1
High-Output Design																					
1	0.75	145T	4.51	J	5.7	2.5	2.8	0.1303	23	51	47.4	49.0	1.25	1150	75.5	80.0	80.0	0.50	0.63	0.72	1.63
1.5	1.1	182T	6.70	J	6.0	2.0	2.6	0.4786	55	121	81.6	52.0	1.25	1160	81.5	84.0	85.5	0.53	0.65	0.72	2.24
2	1.5	184T	6.70	J	6.0	2.0	2.6	0.4786	55	121	81.6	52.0	1.25	1160	81.5	84.0	85.5	0.53	0.65	0.72	2.24
2	1.5	184T	8.93	J	6.0	2.1	2.6	0.5657	47	103	92.6	52.0	1.25	1160	84.0	86.5	86.5	0.54	0.66	0.73	2.98
3	2.2	213T	13.3	H	6.1	1.8	2.4	0.9933	76	167	130	55.0	1.25	1170	84.0	86.5	87.5	0.56	0.68	0.74	4.15
3	2.2	215T	13.3	H	6.1	1.8	2.4	0.9933	76	167	130	55.0	1.25	1170	84.0	86.5	87.5	0.56	0.68	0.74	4.15
5	3.7	215T	22.2	J	6.4	2.1	2.3	1.47	35	77	182	55.0	1.25	1165	86.5	87.5	87.5	0.55	0.67	0.75	7.08
7.5	5.5	254T	33.1	G	6.1	2.0	2.7	2.56	23	51	269	59.0	1.25	1175	87.5	88.5	89.5	0.62	0.74	0.80	9.64
7.5	5.5	256T	33.1	G	6.1	2.0	2.7	2.56	23	51	269	59.0	1.25	1175	87.5	88.5	89.5	0.62	0.74	0.80	9.64
10	7.5	254T	44.3	G	6.0	2.0	2.6	2.90	20	44	293	59.0	1.25	1170	88.5	89.5	89.5	0.63	0.75	0.80	13.1
10	7.5	256T	44.3	G	6.0	2.0	2.6	2.90	20	44	293	59.0	1.25	1170	88.5	89.5	89.5	0.63	0.75	0.80	13.1
15	11	284T	66.1	G	6.0	2.2	2.5	7.20	17	37	408	59.0	1.25	1175	90.2	90.2	90.2	0.72	0.81	0.86	17.8
15	11	284TS	66.1	G	6.0	2.2	2.5	7.20	17	37	408	59.0	1.25	1175	90.2	90.2	90.2	0.72	0.81	0.86	17.8
15	11	286T	66.1	G	6.0	2.2	2.5	7.20	17	37	408	59.0	1.25	1175	90.2	90.2	90.2	0.72	0.81	0.86	17.8
15	11	284/6TS	66.1	G	6.0	2.2	2.5	7.20	17	37	408	59.0	1.25	1175	90.2	90.2	90.2	0.72	0.81	0.86	17.8
20	15	286T	88.2	G	6.1	2.1	2.4	8.18	16	35	454	59.0	1.25	1175	90.2	91.0	91.0	0.73	0.82	0.86	24.1
20	15	284/6TS	88.2	G	6.1	2.1	2.4	8.18	16	35	454	59.0	1.25	1175	90.2	91.0	91.0	0.73	0.82	0.86	24.1
25	18.5	324T	110	F	5.7	2.0	2.4	10.2	19	42	538	62.0	1.25	1175	91.0	91.7	91.7	0.69	0.79	0.83	30.5
25	18.5	324TS	110	F	5.7	2.0	2.4	10.2	19	42	538	62.0	1.25	1175	91.0	91.7	91.7	0.69	0.79	0.83	30.5
25	18.5	326TS	110	F	5.7	2.0	2.4	10.2	19	42	538	62.0	1.25	1175	91.0	91.7	91.7	0.69	0.79	0.83	30.5
30	22	326TS	132	F	5.8	2.0	2.4	11.9	18	40	582	62.0	1.25	1175	91.0	91.7	91.7	0.69	0.79	0.84	35.8
40	30	364/5TS	176	G	6.2	1.9	2.3	23.5	16	35	869	66.0	1.25	1180	93.0	93.0	93.0	0.74	0.83	0.86	47.1





Performance Data

W22 Brake Motor - High Efficiency

Output		Frame	Full Load Torque (ft.lb)	Locked Rotor Current		Locked Rotor Torque Tl/Tn	Break-down Torque Tb/Tn	Inertia J (lb*ft ²)	Allowable locked rotor time (s)		Weight (lb)	Sound dB(A)	Service Factor	460 V						Full load current In (A)	
				Code	ll/In				Rated speed (rpm)	% of full load				Power Factor							
										50				75	100	50	75	100			
HP	kW							Hot	Cold												
VIII Pole																					
1	0.75	182/4T	6.02	K	5.0	2.0	2.6	0.3481	49	108	101	50.0	1.25	860	68.0	72.0	74.0	0.41	0.52	0.62	2.05
1.5	1.1	182/4T	8.98	H	4.7	2.0	2.4	0.3918	37	81	108	50.0	1.25	865	74.0	75.5	77.0	0.44	0.58	0.66	2.72
2	1.5	213/5T	11.9	L	6.6	2.4	2.9	1.19	43	95	161	52.0	1.25	870	78.5	81.5	82.5	0.47	0.53	0.66	3.46
3	2.2	213/5T	18.0	K	7.1	2.0	2.1	2.02	30	66	179	52.0	1.25	865	82.5	84.0	84.0	0.59	0.70	0.76	4.33
5	3.7	254/6T	29.4	H	5.5	2.0	2.6	2.90	33	73	284	54.0	1.25	880	82.5	84.0	85.5	0.48	0.61	0.70	7.76
7.5	5.5	254/6T	44.2	H	5.5	2.0	2.6	3.41	25	55	318	54.0	1.25	880	82.5	85.5	85.5	0.48	0.62	0.70	11.5
10	7.5	284/6T	58.9	G	5.7	2.0	2.2	7.20	30	66	437	54.0	1.25	880	87.5	88.5	88.5	0.67	0.77	0.82	13.0
15	11	284/6T	88.3	G	5.7	2.0	2.2	8.18	22	48	481	54.0	1.25	880	87.5	88.5	88.5	0.68	0.78	0.82	19.0
20	15	324/6T	118	G	5.0	2.0	2.2	9.79	24	53	542	56.0	1.25	880	87.5	89.5	89.5	0.55	0.67	0.74	28.4
25	18.5	324/6T	147	G	5.1	2.2	2.3	11.9	19	42	600	56.0	1.25	880	87.5	89.5	89.5	0.53	0.66	0.73	35.5
30	22	364/5T	177	G	6.0	1.6	2.2	23.5	17	37	875	60.0	1.25	880	91.0	91.7	91.0	0.67	0.77	0.82	37.0
40	30	364/5T	235	G	6.0	1.7	2.2	29.0	13	29	931	60.0	1.25	880	91.0	91.7	91.0	0.67	0.77	0.82	50.5
High-Output Design																					
1	0.75	182T	6.02	K	5.0	2.0	2.6	0.3481	49	108	101	50.0	1.25	860	68.0	72.0	74.0	0.41	0.52	0.62	2.05
1	0.75	184T	6.02	K	5.0	2.0	2.6	0.3481	49	108	101	50.0	1.25	860	68.0	72.0	74.0	0.41	0.52	0.62	2.05
1.5	1.1	184T	8.98	H	4.7	2.0	2.4	0.3918	37	81	108	50.0	1.25	865	74.0	75.5	77.0	0.44	0.58	0.66	2.72
2	1.5	213T	11.9	L	6.6	2.4	2.9	1.19	43	95	161	52.0	1.25	870	78.5	81.5	82.5	0.47	0.53	0.66	3.46
2	1.5	215T	11.9	L	6.6	2.4	2.9	1.19	43	95	161	52.0	1.25	870	78.5	81.5	82.5	0.47	0.53	0.66	3.46
3	2.2	215T	18.0	K	7.1	2.0	2.1	2.02	30	66	179	52.0	1.25	865	82.5	84.0	84.0	0.59	0.70	0.76	4.33
5	3.7	254T	29.4	H	5.5	2.0	2.6	2.90	33	73	284	54.0	1.25	880	82.5	84.0	85.5	0.48	0.61	0.70	7.76
5	3.7	256T	29.4	H	5.5	2.0	2.6	2.90	33	73	284	54.0	1.25	880	82.5	84.0	85.5	0.48	0.61	0.70	7.76
7.5	5.5	256T	44.2	H	5.5	2.0	2.6	3.41	25	55	318	54.0	1.25	880	82.5	85.5	85.5	0.48	0.62	0.70	11.5
10	7.5	284T	58.9	G	5.7	2.0	2.2	7.20	30	66	437	54.0	1.25	880	87.5	88.5	88.5	0.67	0.77	0.82	13.0
10	7.5	284TS	58.9	G	5.7	2.0	2.2	7.20	30	66	437	54.0	1.25	880	87.5	88.5	88.5	0.67	0.77	0.82	13.0
10	7.5	286T	58.9	G	5.7	2.0	2.2	7.20	30	66	437	54.0	1.25	880	87.5	88.5	88.5	0.67	0.77	0.82	13.0
15	11	286T	88.3	G	5.7	2.0	2.2	8.18	22	48	481	54.0	1.25	880	87.5	88.5	88.5	0.68	0.78	0.82	19.0
15	11	284/6TS	88.3	G	5.7	2.0	2.2	8.18	22	48	481	54.0	1.25	880	87.5	88.5	88.5	0.68	0.78	0.82	19.0
20	15	324T	118	G	5.0	2.0	2.2	9.79	24	53	542	56.0	1.25	880	87.5	89.5	89.5	0.55	0.67	0.74	28.4
20	15	324TS	118	G	5.0	2.0	2.2	9.79	24	53	542	56.0	1.25	880	87.5	89.5	89.5	0.55	0.67	0.74	28.4
20	15	326TS	118	G	5.0	2.0	2.2	9.79	24	53	542	56.0	1.25	880	87.5	89.5	89.5	0.55	0.67	0.74	28.4
25	18.5	326T	147	G	5.1	2.2	2.3	11.9	19	42	600	56.0	1.25	880	87.5	89.5	89.5	0.53	0.66	0.73	35.5
25	18.5	326TS	147	G	5.1	2.2	2.3	11.9	19	42	600	56.0	1.25	880	87.5	89.5	89.5	0.53	0.66	0.73	35.5
30	22	364/5TS	177	G	6.0	1.6	2.2	23.5	17	37	875	60.0	1.25	880	91.0	91.7	91.0	0.67	0.77	0.82	37.0
40	30	364/5TS	235	G	6.0	1.7	2.2	29.0	13	29	931	60.0	1.25	880	91.0	91.7	91.0	0.67	0.77	0.82	50.5

W22 Brake Motor - NEMA Premium Efficiency

Output		Frame	Full Load Torque (ft.lb)	Locked Rotor Current		Locked Rotor Torque Tl/Tn	Break-down Torque Tb/Tn	Inertia J (lb*in ²)	Allowable locked rotor time (s)		Weight (lb)	Sound dB(A)	Service Factor	460 V						Full load current In (A)	
				Code	I/In				Hot	Cold				Rated speed (rpm)	% of full load			Power Factor			
															50	75	100	50	75		100
II Pole																					
1	0.75	143/5T	1.48	L	8.2	2.8	3.4	0.0332	22	48	41.9	68.0	1.25	3495	74.0	77.0	78.5	0.69	0.79	0.84	1.43
1.5	1.1	143/5T	2.23	L	8.9	3.5	3.8	0.0470	21	46	46.3	68.0	1.25	3490	81.5	84.0	84.0	0.70	0.80	0.84	1.96
2	1.5	143/5T	2.98	L	8.9	3.5	3.8	0.0605	17	37	57.3	68.0	1.25	3480	82.5	85.5	85.5	0.71	0.80	0.86	2.56
3	2.2	182/4T	4.43	K	8.3	2.4	3.8	0.1889	41	90	101	69.0	1.25	3510	82.5	86.5	86.5	0.75	0.84	0.88	3.63
5	3.7	182/4T	7.40	H	7.5	2.3	3.5	0.2233	25	55	101	69.0	1.25	3500	86.5	88.5	88.5	0.76	0.85	0.89	5.90
7.5	5.5	213/5T	11.0	H	7.2	2.1	3.0	0.4665	27	59	159	72.0	1.25	3520	87.5	89.5	89.5	0.75	0.84	0.88	8.76
10	7.5	213/5T	14.7	H	7.2	2.1	2.9	0.6362	24	53	183	72.0	1.25	3515	89.5	90.2	90.2	0.79	0.87	0.90	11.6
15	11	254/6T	22.0	G	6.7	2.2	2.7	1.26	25	55	278	72.0	1.25	3530	89.5	91.0	91.0	0.77	0.85	0.88	17.2
20	15	254/6T	29.4	G	6.1	2.0	2.4	1.54	21	46	311	72.0	1.25	3520	91.0	91.7	91.0	0.82	0.87	0.89	23.2
25	18.5	284/6TS	36.6	G	6.3	2.0	2.5	2.69	17	37	426	72.0	1.25	3535	91.0	91.7	91.7	0.82	0.87	0.89	28.5
30	22	284/6TS	44.0	G	6.3	2.0	2.5	3.37	15	33	456	72.0	1.25	3535	91.7	91.7	91.7	0.82	0.87	0.89	33.8
High-Output Design																					
1	0.75	143T	1.48	L	8.2	2.8	3.4	0.0332	22	48	41.9	68.0	1.25	3495	74.0	77.0	78.5	0.69	0.79	0.84	1.43
1.5	1.1	143T	2.23	L	8.9	3.5	3.8	0.0470	21	46	46.3	68.0	1.25	3490	81.5	84.0	84.0	0.70	0.80	0.84	1.96
1.5	1.1	145T	2.23	L	8.9	3.5	3.8	0.0470	21	46	46.3	68.0	1.25	3490	81.5	84.0	84.0	0.70	0.80	0.84	1.96
2	1.5	145T	2.98	L	8.9	3.5	3.8	0.0605	17	37	57.3	68.0	1.25	3480	82.5	85.5	85.5	0.71	0.80	0.86	2.56
2	1.5	182T	2.94	L	9.5	2.9	4.8	0.1718	47	103	99.2	69.0	1.25	3530	78.5	84.0	85.5	0.68	0.79	0.84	2.62
3	2.2	143/5T	4.49	J	8.1	3.3	3.6	0.0605	14	31	57.3	68.0	1.25	3460	85.5	86.5	86.5	0.70	0.81	0.86	3.71
3	2.2	145T	4.49	J	8.1	3.3	3.6	0.0605	14	31	57.3	68.0	1.25	3460	85.5	86.5	86.5	0.70	0.81	0.86	3.71
3	2.2	182T	4.43	K	8.3	2.4	3.8	0.1889	41	90	101	69.0	1.25	3510	82.5	86.5	86.5	0.75	0.84	0.88	3.63
3	2.2	184T	4.43	K	8.3	2.4	3.8	0.1889	41	90	101	69.0	1.25	3510	82.5	86.5	86.5	0.75	0.84	0.88	3.63
5	3.7	184T	7.40	H	7.5	2.3	3.5	0.2233	25	55	101	69.0	1.25	3500	86.5	88.5	88.5	0.76	0.85	0.89	5.90
7.5	5.5	182/4T	11.1	J	8.2	2.7	3.3	0.2242	17	37	106	69.0	1.25	3485	88.5	89.5	89.5	0.75	0.84	0.88	8.76
7.5	5.5	184T	11.1	J	8.2	2.7	3.3	0.2242	17	37	106	69.0	1.25	3485	88.5	89.5	89.5	0.75	0.84	0.88	8.76
7.5	5.5	213T	11.0	H	7.2	2.1	3.0	0.4665	27	59	159	72.0	1.25	3520	87.5	89.5	89.5	0.75	0.84	0.88	8.76
7.5	5.5	215T	11.0	H	7.2	2.1	3.0	0.4665	27	59	159	72.0	1.25	3520	87.5	89.5	89.5	0.75	0.84	0.88	8.76
10	7.5	215T	14.7	H	7.2	2.1	2.9	0.6362	24	53	183	72.0	1.25	3515	89.5	90.2	90.2	0.79	0.87	0.90	11.6
15	11	213/5T	22.1	H	7.6	2.4	2.8	0.6362	14	31	183	72.0	1.25	3510	90.2	91.0	91.0	0.76	0.85	0.89	17.0
15	11	215T	22.1	H	7.6	2.4	2.8	0.6362	14	31	183	72.0	1.25	3510	90.2	91.0	91.0	0.76	0.85	0.89	17.0
15	11	254T	22.0	G	6.7	2.2	2.7	1.26	25	55	278	72.0	1.25	3530	89.5	91.0	91.0	0.77	0.85	0.88	17.2
15	11	256T	22.0	G	6.7	2.2	2.7	1.26	25	55	278	72.0	1.25	3530	89.5	91.0	91.0	0.77	0.85	0.88	17.2
20	15	256T	29.4	G	6.1	2.0	2.4	1.54	21	46	311	72.0	1.25	3520	91.0	91.7	91.0	0.82	0.87	0.89	23.2
25	18.5	284TS	36.6	G	6.3	2.0	2.5	2.69	17	37	426	72.0	1.25	3535	91.0	91.7	91.7	0.82	0.87	0.89	28.5
25	18.5	284/6T	36.6	G	6.3	2.0	2.5	2.69	17	37	426	72.0	1.25	3535	91.0	91.7	91.7	0.82	0.87	0.89	28.5
30	22	286TS	44.0	G	6.3	2.0	2.5	3.37	15	33	456	72.0	1.25	3535	91.7	91.7	91.7	0.82	0.87	0.89	33.8
30	22	284/6T	44.0	G	6.3	2.0	2.5	3.37	15	33	456	72.0	1.25	3535	91.7	91.7	91.7	0.82	0.87	0.89	33.8



Performance Data

W22 Brake Motor - NEMA Premium Efficiency

Output		Frame	Full Load Torque (ft.lb)	Locked Rotor Current		Locked Rotor Torque Tl/Tn	Break-down Torque Tb/Tn	Inertia J (lb*ft²)	Allowable locked rotor time (s)		Weight (lb)	Sound dB(A)	Service Factor	460 V						Full load current In (A)	
				Code	II/In				Hot	Cold				Rated speed (rpm)	% of full load			Power Factor			
															50	75	100	50	75		100
IV Pole																					
1	0.75	143/5T	2.94	L	8.4	2.8	3.5	0.1172	18	40	46.3	51.0	1.25	1760	80.0	84.0	85.5	0.60	0.70	0.78	1.41
1.5	1.1	143/5T	4.43	K	8.3	2.5	3.4	0.1431	14	31	54.0	51.0	1.25	1755	82.5	85.5	86.5	0.60	0.70	0.79	2.02
2	1.5	143/5T	5.92	K	8.0	2.6	3.0	0.1561	11	24	56.2	51.0	1.25	1750	85.5	86.5	86.5	0.62	0.74	0.81	2.69
3	2.2	182/4T	8.83	K	8.1	2.3	3.4	0.3401	23	51	104	56.0	1.25	1760	87.5	88.5	89.5	0.61	0.73	0.79	3.91
5	3.7	182/4T	14.8	J	7.2	2.3	3.2	0.4003	15	33	108	56.0	1.25	1755	88.5	89.5	89.5	0.62	0.74	0.80	6.45
10	7.5	213/5T	29.4	H	6.4	2.0	3.0	1.51	17	37	192	58.0	1.25	1760	90.2	91.7	91.7	0.66	0.77	0.83	12.4
15	11	254/6T	44.0	G	6.5	2.3	2.7	2.62	17	37	293	64.0	1.25	1765	91.0	91.7	92.4	0.68	0.78	0.83	18.0
20	15	254/6T	58.7	G	6.5	2.3	2.7	3.10	15	33	333	64.0	1.25	1765	91.7	92.4	93.0	0.68	0.79	0.84	24.1
25	18.5	284/6T	73.4	G	6.2	2.4	2.7	5.11	24	53	452	64.0	1.25	1765	92.4	93.0	93.6	0.70	0.80	0.84	29.5
30	22	284/6T	88.1	G	6.1	2.4	2.4	5.85	20	44	501	64.0	1.25	1765	93.0	93.0	93.6	0.70	0.80	0.84	35.1
40	30	324/6T	117	G	6.1	2.2	2.4	9.16	20	44	582	66.0	1.25	1770	93.6	94.1	94.1	0.72	0.80	0.85	47.1
50	37	324/6T	146	G	6.2	2.3	2.7	9.16	15	33	626	66.0	1.25	1775	93.0	94.1	94.5	0.66	0.77	0.83	59.2
60	45	364/5T	175	G	6.6	2.4	2.6	22.4	15	33	968	67.0	1.25	1775	94.1	94.5	95.0	0.75	0.83	0.87	68.3
75	55	364/5T	219	G	6.4	2.4	2.6	23.3	14	31	1019	67.0	1.25	1775	94.5	95.0	95.4	0.73	0.82	0.86	84.1
High-Output Design																					
1	0.75	143T	2.94	L	8.4	2.8	3.5	0.1172	18	40	46.3	51.0	1.25	1760	80.0	84.0	85.5	0.60	0.70	0.78	1.41
1	0.75	145T	2.94	L	8.4	2.8	3.5	0.1172	18	40	46.3	51.0	1.25	1760	80.0	84.0	85.5	0.60	0.70	0.78	1.41
1.5	1.1	145T	4.43	K	8.3	2.5	3.4	0.1431	14	31	54.0	51.0	1.25	1755	82.5	85.5	86.5	0.60	0.70	0.79	2.02
2	1.5	145T	5.92	K	8.0	2.6	3.0	0.1561	11	24	56.2	51.0	1.25	1750	85.5	86.5	86.5	0.62	0.74	0.81	2.69
3	2.2	182T	8.83	K	8.1	2.3	3.4	0.3401	23	51	104	56.0	1.25	1760	87.5	88.5	89.5	0.61	0.73	0.79	3.91
3	2.2	184T	8.83	K	8.1	2.3	3.4	0.3401	23	51	104	56.0	1.25	1760	87.5	88.5	89.5	0.61	0.73	0.79	3.91
5	3.7	184T	14.8	J	7.2	2.3	3.2	0.4003	15	33	108	56.0	1.25	1755	88.5	89.5	89.5	0.62	0.74	0.80	6.45
5	3.7	213T	14.7	J	7.1	2.3	3.2	1.07	20	44	152	58.0	1.25	1765	88.5	89.5	89.5	0.64	0.75	0.81	6.41
10	7.5	215T	29.4	H	6.4	2.0	3.0	1.51	17	37	192	58.0	1.25	1760	90.2	91.7	91.7	0.66	0.77	0.83	12.4
15	11	254T	44.0	G	6.5	2.3	2.7	2.62	17	37	293	64.0	1.25	1765	91.0	91.7	92.4	0.68	0.78	0.83	18.0
15	11	256T	44.0	G	6.5	2.3	2.7	2.62	17	37	293	64.0	1.25	1765	91.0	91.7	92.4	0.68	0.78	0.83	18.0
20	15	256T	58.7	G	6.5	2.3	2.7	3.10	15	33	333	64.0	1.25	1765	91.7	92.4	93.0	0.68	0.79	0.84	24.1
20	15	284T	58.7	G	6.0	2.3	2.6	5.11	27	59	434	64.0	1.25	1765	92.4	93.0	93.0	0.70	0.80	0.84	24.1
20	15	284TS	58.7	G	6.0	2.3	2.6	5.11	27	59	434	64.0	1.25	1765	92.4	93.0	93.0	0.70	0.80	0.84	24.1
20	15	284/6T	58.7	G	6.0	2.3	2.6	5.11	27	59	434	64.0	1.25	1765	92.4	93.0	93.0	0.70	0.80	0.84	24.1
25	18.5	284T	73.4	G	6.2	2.4	2.7	5.11	24	53	452	64.0	1.25	1765	92.4	93.0	93.6	0.70	0.80	0.84	29.5
25	18.5	284TS	73.4	G	6.2	2.4	2.7	5.11	24	53	452	64.0	1.25	1765	92.4	93.0	93.6	0.70	0.80	0.84	29.5
25	18.5	286T	73.4	G	6.2	2.4	2.7	5.11	24	53	452	64.0	1.25	1765	92.4	93.0	93.6	0.70	0.80	0.84	29.5
25	18.5	284/6TS	73.4	G	6.2	2.4	2.7	5.11	24	53	452	64.0	1.25	1765	92.4	93.0	93.6	0.70	0.80	0.84	29.5
30	22	286T	88.1	G	6.1	2.4	2.4	5.85	20	44	501	64.0	1.25	1765	93.0	93.0	93.6	0.70	0.80	0.84	35.1
30	22	324T	87.6	G	6.2	2.1	2.4	8.18	26	57	553	66.0	1.25	1775	92.4	93.6	93.6	0.72	0.81	0.84	35.1
30	22	324TS	87.6	G	6.2	2.1	2.4	8.18	26	57	553	66.0	1.25	1775	92.4	93.6	93.6	0.72	0.81	0.84	35.1
30	22	284/6TS	88.1	G	6.1	2.4	2.4	5.85	20	44	501	64.0	1.25	1765	93.0	93.0	93.6	0.70	0.80	0.84	35.1
40	30	324T	117	G	6.1	2.2	2.4	9.16	20	44	582	66.0	1.25	1770	93.6	94.1	94.1	0.72	0.80	0.85	47.1
40	30	324TS	117	G	6.1	2.2	2.4	9.16	20	44	582	66.0	1.25	1770	93.6	94.1	94.1	0.72	0.80	0.85	47.1
40	30	326T	117	G	6.1	2.2	2.4	9.16	20	44	582	66.0	1.25	1770	93.6	94.1	94.1	0.72	0.80	0.85	47.1
40	30	326TS	117	G	6.1	2.2	2.4	9.16	20	44	582	66.0	1.25	1770	93.6	94.1	94.1	0.72	0.80	0.85	47.1
50	37	326T	146	G	6.2	2.3	2.7	9.16	15	33	626	66.0	1.25	1775	93.0	94.1	94.5	0.66	0.77	0.83	59.2
50	37	326TS	146	G	6.2	2.3	2.7	9.16	15	33	626	66.0	1.25	1775	93.0	94.1	94.5	0.66	0.77	0.83	59.2
60	45	364/5TS	175	G	6.6	2.4	2.6	22.4	15	33	968	67.0	1.25	1775	94.1	94.5	95.0	0.75	0.83	0.87	68.3

W22 Brake Motor - NEMA Premium Efficiency

Output		Frame	Full Load Torque (ft.lb)	Locked Rotor Current		Locked Rotor Torque Tl/Tn	Break-down Torque Tb/Tn	Inertia J (lb*ft²)	Allowable locked rotor time (s)		Weight (lb)	Sound dB(A)	Service Factor	Rated speed (rpm)	460 V						Full load current In (A)
				Code	II/In				% of full load						Power Factor						
									50	75					100	50	75	100			
VI Pole																					
1	0.75	143/5T	4.51	K	6.2	3.0	3.0	0.1595	28	62	58.4	49.0	1.25	1150	77.0	82.0	82.5	0.45	0.57	0.66	1.73
1.5	1.1	182/4T	6.67	M	8.0	3.2	4.0	0.4879	16	35	83.6	52.0	1.25	1165	84.0	86.5	87.5	0.45	0.54	0.62	2.54
2	1.5	182/4T	8.89	L	7.5	3.0	3.0	0.6210	31	68	101	52.0	1.25	1165	86.5	88.5	88.5	0.46	0.58	0.66	3.23
3	2.2	213/5T	13.3	K	7.0	2.0	2.8	1.20	58	128	141	55.0	1.25	1170	86.5	88.5	89.5	0.50	0.63	0.70	4.41
5	3.7	213/5T	22.1	J	6.6	1.9	2.4	1.47	57	125	182	55.0	1.25	1170	88.5	89.5	89.5	0.58	0.70	0.76	6.83
7.5	5.5	254/6T	33.1	H	6.8	2.5	3.0	3.92	30	66	304	59.0	1.25	1175	89.5	90.2	91.0	0.63	0.74	0.80	9.48
10	7.5	254/6T	44.1	H	6.5	2.3	2.8	4.43	26	57	331	59.0	1.25	1175	90.2	91.0	91.0	0.63	0.74	0.80	12.9
15	11	284/6T	66.1	H	6.7	2.3	2.7	7.85	20	44	443	59.0	1.25	1175	91.0	91.7	91.7	0.69	0.80	0.84	17.9
20	15	284/6T	88.2	G	6.2	2.3	2.6	9.16	16	35	490	59.0	1.25	1175	91.0	91.7	91.7	0.70	0.80	0.85	24.2
25	18.5	324/6T	110	G	6.2	2.1	2.6	11.5	26	57	650	62.0	1.25	1180	91.7	93.0	93.0	0.65	0.77	0.82	30.4
30	22	324/6T	132	G	6.2	2.3	2.6	13.2	21	46	644	62.0	1.25	1180	91.7	93.0	93.0	0.65	0.77	0.83	35.8
40	30	364/5T	176	G	6.4	2.0	2.4	29.0	21	46	933	66.0	1.25	1180	93.6	93.6	94.1	0.73	0.82	0.86	46.5
50	37	364/5T	220	G	6.4	2.0	2.4	32.4	18	40	968	66.0	1.25	1180	93.6	94.1	94.1	0.74	0.83	0.86	57.4
High-Output Design																					
1	0.75	145T	4.51	K	6.2	3.0	3.0	0.1595	28	62	58.4	49.0	1.25	1150	77.0	82.0	82.5	0.45	0.57	0.66	1.73
1.5	1.1	182T	6.67	M	8.0	3.2	4.0	0.4879	16	35	83.6	52.0	1.25	1165	84.0	86.5	87.5	0.45	0.54	0.62	2.54
2	1.5	184T	8.89	L	7.5	3.0	3.0	0.6210	31	68	101	52.0	1.25	1165	86.5	88.5	88.5	0.46	0.58	0.66	3.23
3	2.2	213T	13.3	K	7.0	2.0	2.8	1.20	58	128	141	55.0	1.25	1170	86.5	88.5	89.5	0.50	0.63	0.70	4.41
3	2.2	215T	13.3	K	7.0	2.0	2.8	1.20	58	128	141	55.0	1.25	1170	86.5	88.5	89.5	0.50	0.63	0.70	4.41
5	3.7	215T	22.1	J	6.6	1.9	2.4	1.47	57	125	182	55.0	1.25	1170	88.5	89.5	89.5	0.58	0.70	0.76	6.83
7.5	5.5	254T	33.1	H	6.8	2.5	3.0	3.92	30	66	304	59.0	1.25	1175	89.5	90.2	91.0	0.63	0.74	0.80	9.48
7.5	5.5	256T	33.1	H	6.8	2.5	3.0	3.92	30	66	304	59.0	1.25	1175	89.5	90.2	91.0	0.63	0.74	0.80	9.48
10	7.5	254T	44.1	H	6.5	2.3	2.8	4.43	26	57	331	59.0	1.25	1175	90.2	91.0	91.0	0.63	0.74	0.80	12.9
10	7.5	256T	44.1	H	6.5	2.3	2.8	4.43	26	57	331	59.0	1.25	1175	90.2	91.0	91.0	0.63	0.74	0.80	12.9
15	11	284T	66.1	H	6.7	2.3	2.7	7.85	20	44	443	59.0	1.25	1175	91.0	91.7	91.7	0.69	0.80	0.84	17.9
15	11	284TS	66.1	H	6.7	2.3	2.7	7.85	20	44	443	59.0	1.25	1175	91.0	91.7	91.7	0.69	0.80	0.84	17.9
15	11	286T	66.1	H	6.7	2.3	2.7	7.85	20	44	443	59.0	1.25	1175	91.0	91.7	91.7	0.69	0.80	0.84	17.9
15	11	284/6TS	66.1	H	6.7	2.3	2.7	7.85	20	44	443	59.0	1.25	1175	91.0	91.7	91.7	0.69	0.80	0.84	17.9
20	15	284/6TS	88.2	G	6.2	2.3	2.6	9.16	16	35	490	59.0	1.25	1175	91.0	91.7	91.7	0.70	0.80	0.85	24.2
25	18.5	324T	110	G	6.2	2.1	2.6	11.5	26	57	650	62.0	1.25	1180	91.7	93.0	93.0	0.65	0.77	0.82	30.4
25	18.5	324TS	110	G	6.2	2.1	2.6	11.5	26	57	650	62.0	1.25	1180	91.7	93.0	93.0	0.65	0.77	0.82	30.4
25	18.5	326T	110	G	6.2	2.1	2.6	11.5	26	57	650	62.0	1.25	1180	91.7	93.0	93.0	0.65	0.77	0.82	30.4
25	18.5	326TS	110	G	6.2	2.1	2.6	11.5	26	57	650	62.0	1.25	1180	91.7	93.0	93.0	0.65	0.77	0.82	30.4
30	22	326T	132	G	6.2	2.3	2.6	13.2	21	46	644	62.0	1.25	1180	91.7	93.0	93.0	0.65	0.77	0.83	35.8
30	22	326TS	132	G	6.2	2.3	2.6	13.2	21	46	644	62.0	1.25	1180	91.7	93.0	93.0	0.65	0.77	0.83	35.8
30	22	364/5T	132	G	6.2	1.9	2.4	13.2	27	59	880	66.0	1.25	1180	93.0	93.6	93.0	0.72	0.81	0.85	34.9
30	22	364/5TS	132	G	6.2	1.9	2.4	13.2	27	59	880	66.0	1.25	1180	93.0	93.6	93.0	0.72	0.81	0.85	34.9
40	30	364/5TS	176	G	6.4	2.0	2.4	29.0	21	46	933	66.0	1.25	1180	93.6	93.6	94.1	0.73	0.82	0.86	46.5
50	37	364/5TS	220	G	6.4	2.0	2.4	32.4	18	40	968	66.0	1.25	1180	93.6	94.1	94.1	0.74	0.83	0.86	57.4

Performance Data

W22 Brake Motor - NEMA Premium Efficiency

Output		Frame	Full Load Torque (ft.lb)	Locked Rotor Current		Locked Rotor Torque Tl/Tn	Break-down Torque Tb/Tn	Inertia J (lb*ft²)	Allowable locked rotor time (s)		Weight (lb)	Sound dB(A)	Service Factor	460 V						Full load current In (A)	
				Code	II/In				% of full load												
									Rated speed (rpm)	Efficiency				Power Factor							
HP	kW																				
VIII Pole																					
1	0.75	182/4T	5.92	M	6.0	3.0	3.5	0.3991	22	48	108	50.0	1.25	875	74.0	77.0	78.5	0.32	0.42	0.52	2.30
1.5	1.1	182/4T	9.04	J	5.5	2.5	2.6	0.5766	17	37	124	50.0	1.25	860	80.0	82.5	82.5	0.43	0.54	0.62	2.70
2	1.5	213/5T	11.9	M	7.6	2.4	2.9	1.79	39	86	169	52.0	1.25	870	82.5	84.0	85.5	0.45	0.55	0.65	3.39
3	2.2	213/5T	18.0	K	6.8	2.3	2.8	2.11	44	97	196	52.0	1.25	865	84.0	85.5	85.5	0.50	0.63	0.71	4.56
5	3.7	254/6T	29.4	H	5.3	1.9	2.5	3.41	44	97	300	54.0	1.25	880	85.5	87.5	87.5	0.49	0.62	0.70	7.58
7.5	5.5	254/6T	44.2	G	5.3	2.0	2.5	4.43	33	73	326	54.0	1.25	880	85.5	87.5	87.5	0.50	0.63	0.71	11.1
10	7.5	284/6T	58.9	G	5.6	2.0	2.4	7.20	32	70	437	54.0	1.25	880	89.5	90.2	90.2	0.61	0.72	0.78	13.4
15	11	284/6T	88.3	G	5.5	2.0	2.3	8.18	25	55	481	54.0	1.25	880	90.2	91.0	90.2	0.62	0.73	0.79	19.4
20	15	324/6T	118	G	5.0	1.9	2.2	9.37	27	59	542	56.0	1.25	880	89.5	91.0	91.0	0.54	0.66	0.73	28.3
25	18.5	324/6T	147	G	5.2	2.0	2.3	11.9	23	51	600	56.0	1.25	880	89.5	91.0	91.0	0.51	0.64	0.71	35.9
30	22	364/5T	177	G	6.2	1.7	2.4	23.5	20	44	902	60.0	1.25	880	92.4	92.4	92.4	0.63	0.74	0.80	37.0
40	30	364/5T	235	G	6.0	1.7	2.3	29.0	18	40	975	60.0	1.25	880	92.4	93.0	92.4	0.66	0.76	0.81	50.0

High-Output Design																					
1	0.75	182T	5.92	M	6.0	3.0	3.5	0.3991	22	48	108	50.0	1.25	875	74.0	77.0	78.5	0.32	0.42	0.52	2.30
1	0.75	184T	5.92	M	6.0	3.0	3.5	0.3991	22	48	108	50.0	1.25	875	74.0	77.0	78.5	0.32	0.42	0.52	2.30
1.5	1.1	184T	9.04	J	5.5	2.5	2.6	0.5766	17	37	124	50.0	1.25	860	80.0	82.5	82.5	0.43	0.54	0.62	2.70
2	1.5	213T	11.9	M	7.6	2.4	2.9	1.79	39	86	169	52.0	1.25	870	82.5	84.0	85.5	0.45	0.55	0.65	3.39
2	1.5	215T	11.9	M	7.6	2.4	2.9	1.79	39	86	169	52.0	1.25	870	82.5	84.0	85.5	0.45	0.55	0.65	3.39
3	2.2	215T	18.0	K	6.8	2.3	2.8	2.11	44	97	196	52.0	1.25	865	84.0	85.5	85.5	0.50	0.63	0.71	4.56
5	3.7	254T	29.4	H	5.3	1.9	2.5	3.41	44	97	300	54.0	1.25	880	85.5	87.5	87.5	0.49	0.62	0.70	7.58
5	3.7	256T	29.4	H	5.3	1.9	2.5	3.41	44	97	300	54.0	1.25	880	85.5	87.5	87.5	0.49	0.62	0.70	7.58
7.5	5.5	256T	44.2	G	5.3	2.0	2.5	4.43	33	73	326	54.0	1.25	880	85.5	87.5	87.5	0.50	0.63	0.71	11.1
7.5	5.5	284T	44.2	G	5.6	2.0	2.4	7.20	34	75	408	54.0	1.25	880	87.5	88.5	88.5	0.60	0.72	0.78	10.0
7.5	5.5	284TS	44.2	G	5.6	2.0	2.4	7.20	34	75	408	54.0	1.25	880	87.5	88.5	88.5	0.60	0.72	0.78	10.0
10	7.5	284T	58.9	G	5.6	2.0	2.4	7.20	32	70	437	54.0	1.25	880	89.5	90.2	90.2	0.61	0.72	0.78	13.4
10	7.5	284TS	58.9	G	5.6	2.0	2.4	7.20	32	70	437	54.0	1.25	880	89.5	90.2	90.2	0.61	0.72	0.78	13.4
15	11	286T	88.3	G	5.5	2.0	2.3	8.18	25	55	481	54.0	1.25	880	90.2	91.0	90.2	0.62	0.73	0.79	19.4
15	11	284/6TS	88.3	G	5.5	2.0	2.3	8.18	25	55	481	54.0	1.25	880	90.2	91.0	90.2	0.62	0.73	0.79	19.4
20	15	324TS	118	G	5.0	1.9	2.2	9.37	27	59	542	56.0	1.25	880	89.5	91.0	91.0	0.54	0.66	0.73	28.3
25	18.5	326TS	147	G	5.2	2.0	2.3	11.9	23	51	600	56.0	1.25	880	89.5	91.0	91.0	0.51	0.64	0.71	35.9
30	22	364/5TS	177	G	6.2	1.7	2.4	23.5	20	44	902	60.0	1.25	880	92.4	92.4	92.4	0.63	0.74	0.80	37.0
40	30	364/5TS	235	G	6.0	1.7	2.3	29.0	18	40	975	60.0	1.25	880	92.4	93.0	92.4	0.66	0.76	0.81	50.0

W22 Brake Motor - Super Premium Efficiency

Output		Frame	Full Load Torque (ft.lb)	Locked Rotor Current		Locked Rotor Torque Tl/Tn	Break-down Torque Tb/Tn	Inertia J (lb*ft²)	Allowable locked rotor time (s)		Weight (lb)	Sound dB(A)	Service Factor	460 V						Full load current In (A)	
				Code	II/In				% of full load												
									Rated speed (rpm)	Efficiency				Power Factor							
HP	kW																				
II Pole																					
1	0.75	143/5T	1.49	J	7.2	2.5	3.0	0.0413	36	79	45.2	68.0	1.25	3485	81.5	82.5	84.0	0.69	0.79	0.83	1.35
1.5	1.1	143/5T	2.23	K	8.4	3.0	3.5	0.0468	29	64	47.4	68.0	1.25	3485	84.0	85.5	86.5	0.67	0.78	0.83	1.92
2	1.5	143/5T	2.97	K	8.2	3.2	3.6	0.0605	23	51	56.2	68.0	1.25	3490	85.5	87.5	87.5	0.69	0.80	0.84	2.56
3	2.2	182/4T	4.42	K	8.5	2.4	3.6	0.1889	50	110	101	69.0	1.25	3520	84.0	86.5	88.5	0.70	0.81	0.85	3.67
5	3.7	182/4T	7.39	J	8.2	2.4	3.5	0.2233	30	66	108	69.0	1.25	3505	87.5	88.5	90.2	0.73	0.83	0.86	5.99
7.5	5.5	213/5T	11.0	J	7.6	2.3	3.3	0.5512	37	81	161	72.0	1.25	3530	87.5	89.5	91.0	0.73	0.82	0.86	8.82
10	7.5	213/5T	14.7	J	8.0	2.4	3.2	0.7209	34	75	192	72.0	1.25	3535	89.5	91.0	91.7	0.77	0.85	0.89	11.5
15	11	254/6T	21.9	J	7.7	2.7	3.5	1.18	28	62	315	72.0	1.25	3545	90.2	91.7	92.4	0.72	0.82	0.86	17.4
20	15	254/6T	29.2	H	7.6	2.6	3.4	1.44	23	51	353	72.0	1.25	3545	91.0	92.4	93.0	0.75	0.84	0.88	23.0
25	18.5	284/6T	36.5	H	7.5	2.4	3.3	2.68	20	44	450	72.0	1.25	3550	91.7	93.0	93.6	0.75	0.83	0.87	28.5
30	22	284/6T	43.8	H	7.5	2.4	3.3	3.19	19	42	501	72.0	1.25	3550	92.4	93.6	93.6	0.76	0.84	0.88	33.5

High-Output Design																					
1	0.75	143T	1.49	J	7.2	2.5	3.0	0.0413	36	79	45.2	68.0	1.25	3485	81.5	82.5	84.0	0.69	0.79	0.83	1.35
1.5	1.1	143T	2.23	K	8.4	3.0	3.5	0.0468	29	64	47.4	68.0	1.25	3485	84.0	85.5	86.5	0.67	0.78	0.83	1.92
2	1.5	145T	2.97	K	8.2	3.2	3.6	0.0605	23	51	56.2	68.0	1.25	3490	85.5	87.5	87.5	0.69	0.80	0.84	2.56
3	2.2	182T	4.42	K	8.5	2.4	3.6	0.1889	50	110	101	69.0	1.25	3520	84.0	86.5	88.5	0.70	0.81	0.85	3.67
5	3.7	184T	7.39	J	8.2	2.4	3.5	0.2233	30	66	108	69.0	1.25	3505	87.5	88.5	90.2	0.73	0.83	0.86	5.99
7.5	5.5	213T	11.0	J	7.6	2.3	3.3	0.5512	37	81	161	72.0	1.25	3530	87.5	89.5	91.0	0.73	0.82	0.86	8.82
10	7.5	215T	14.7	J	8.0	2.4	3.2	0.7209	34	75	192	72.0	1.25	3535	89.5	91.0	91.7	0.77	0.85	0.89	11.5
15	11	254T	21.9	J	7.7	2.7	3.5	1.18	28	62	315	72.0	1.25	3545	90.2	91.7	92.4	0.72	0.82	0.86	17.4
20	15	256T	29.2	H	7.6	2.6	3.4	1.44	23	51	353	72.0	1.25	3545	91.0	92.4	93.0	0.75	0.84	0.88	23.0
25	18.5	284T	36.5	H	7.5	2.4	3.3	2.68	20	44	450	72.0	1.25	3550	91.7	93.0	93.6	0.75	0.83	0.87	28.5
25	18.5	284TS	36.5	H	7.5	2.4	3.3	2.68	20	44	450	72.0	1.25	3550	91.7	93.0	93.6	0.75	0.83	0.87	28.5
30	22	284/6TS	43.8	H	7.5	2.4	3.3	3.19	19	42	501	72.0	1.25	3550	92.4	93.6	93.6	0.76	0.84	0.88	33.5

W22 Brake Motor - Super Premium Efficiency

Output		Frame	Full Load Torque (ft.lb)	Locked Rotor Current		Locked Rotor Torque Tl/Tn	Break-down Torque Tb/Tn	Inertia J (lb*ff ²)	Allowable locked rotor time (s)		Weight (lb)	Sound dB(A)	Service Factor	460 V								
														Rated speed (rpm)	% of full load						Full load current In (A)	
															Efficiency			Power Factor				
HP	KW			Code	II/In				Hot	Cold					50	75	100	50	75	100		
IV Pole																						
1	0.75	143/5T	2.94	L	9.0	2.6	3.3	0.1561	33	73	56.2	51.0	1.25	1760	84.0	86.5	87.5	0.59	0.70	0.79	1.33	
3	2.2	182/4T	8.81	J	7.7	2.3	3.2	0.4017	36	79	106	56.0	1.25	1765	87.5	88.5	91.0	0.63	0.75	0.81	3.76	
7.5	5.5	213/5T	22.0	K	8.5	2.3	3.5	1.51	20	44	192	58.0	1.25	1770	91.0	92.4	93.0	0.65	0.76	0.83	8.94	
15	11	254/6T	43.8	K	8.5	2.8	3.3	2.55	20	44	322	64.0	1.25	1775	91.7	93.0	93.6	0.66	0.76	0.83	17.8	
20	15	254/6T	58.5	J	7.4	2.6	3.0	4.29	30	66	368	64.0	1.25	1770	93.0	93.6	94.1	0.63	0.75	0.81	24.7	
25	18.5	284/6T	73.0	K	8.3	3.0	3.4	4.94	26	57	470	64.0	1.25	1775	93.0	94.1	94.5	0.62	0.74	0.81	30.3	
30	22	284/6T	87.6	J	8.0	3.2	3.5	5.67	25	55	514	64.0	1.25	1775	93.0	94.1	94.5	0.64	0.76	0.82	35.6	
40	30	324/6T	116	J	7.4	2.6	3.0	8.83	22	48	624	66.0	1.25	1780	93.6	94.5	95.0	0.64	0.75	0.81	48.9	
50	37	324/6T	146	H	7.4	2.6	3.0	9.40	20	44	688	66.0	1.25	1780	94.1	95.0	95.4	0.62	0.73	0.81	60.1	
60	45	364/5T	175	J	8.5	2.7	3.2	23.3	24	53	997	67.0	1.25	1780	94.5	95.4	95.8	0.69	0.80	0.84	70.2	
75	55	364/5T	218	J	8.4	2.8	3.2	23.3	16	35	1019	67.0	1.25	1780	94.5	95.4	95.8	0.68	0.78	0.83	86.8	
High-Output Design																						
15	11	254T	43.8	K	8.5	2.8	3.3	2.55	20	44	322	64.0	1.25	1775	91.7	93.0	93.6	0.66	0.76	0.83	17.8	
20	15	256T	58.5	J	7.4	2.6	3.0	4.29	30	66	368	64.0	1.25	1770	93.0	93.6	94.1	0.63	0.75	0.81	24.7	
25	18.5	284T	73.0	K	8.3	3.0	3.4	4.94	26	57	470	64.0	1.25	1775	93.0	94.1	94.5	0.62	0.74	0.81	30.3	
25	18.5	284TS	73.0	K	8.3	3.0	3.4	4.94	26	57	470	64.0	1.25	1775	93.0	94.1	94.5	0.62	0.74	0.81	30.3	
30	22	286T	87.6	J	8.0	3.2	3.5	5.67	25	55	514	64.0	1.25	1775	93.0	94.1	94.5	0.64	0.76	0.82	35.6	
30	22	284/6TS	87.6	J	8.0	3.2	3.5	5.67	25	55	514	64.0	1.25	1775	93.0	94.1	94.5	0.64	0.76	0.82	35.6	
40	30	324T	116	J	7.4	2.6	3.0	8.83	22	48	624	66.0	1.25	1780	93.6	94.5	95.0	0.64	0.75	0.81	48.9	
40	30	324TS	116	J	7.4	2.6	3.0	8.83	22	48	624	66.0	1.25	1780	93.6	94.5	95.0	0.64	0.75	0.81	48.9	
50	37	326T	146	H	7.4	2.6	3.0	9.40	20	44	688	66.0	1.25	1780	94.1	95.0	95.4	0.62	0.73	0.81	60.1	
50	37	326TS	146	H	7.4	2.6	3.0	9.40	20	44	688	66.0	1.25	1780	94.1	95.0	95.4	0.62	0.73	0.81	60.1	
60	45	364/5TS	175	J	8.5	2.7	3.2	23.3	24	53	997	67.0	1.25	1780	94.5	95.4	95.8	0.69	0.80	0.84	70.2	
75	55	364/5TS	218	J	8.4	2.8	3.2	23.3	16	35	1019	67.0	1.25	1780	94.5	95.4	95.8	0.68	0.78	0.83	86.8	
VI Pole																						
3	2.2	213/5T	13.2	J	6.6	1.8	2.9	1.53	90	198	192	55.0	1.25	1175	87.5	89.5	90.2	0.51	0.63	0.71	4.30	
7.5	5.5	254/6T	33.1	H	6.8	2.5	3.1	3.66	50	110	346	59.0	1.25	1175	90.2	91.7	92.4	0.60	0.72	0.79	9.46	
10	7.5	254/6T	43.9	H	6.8	2.4	3.0	4.32	40	88	386	59.0	1.25	1180	91.0	92.4	92.4	0.62	0.74	0.80	12.7	
15	11	284/6T	65.9	H	7.1	2.6	3.0	7.69	25	55	474	59.0	1.25	1180	91.7	92.4	93.0	0.65	0.76	0.82	18.1	
20	15	284/6T	87.8	J	7.4	2.7	3.0	9.29	20	44	538	59.0	1.25	1180	91.7	92.4	93.0	0.67	0.78	0.83	24.4	
25	18.5	324/6T	109	J	7.3	2.6	3.1	11.2	30	66	617	62.0	1.25	1185	92.4	93.6	94.1	0.61	0.73	0.80	30.8	
30	22	324/6T	131	H	7.0	2.6	3.0	12.9	27	59	675	62.0	1.25	1185	92.4	93.6	94.1	0.60	0.73	0.80	36.7	
40	30	364/5T	175	K	8.4	2.6	3.2	32.7	22	48	975	66.0	1.25	1185	93.6	94.5	95.0	0.64	0.76	0.81	48.9	
50	37	364/5T	219	K	8.5	2.6	3.3	33.7	12	26	994	66.0	1.25	1185	93.6	94.5	95.0	0.63	0.75	0.81	60.3	
High-Output Design																						
7.5	5.5	254T	33.1	H	6.8	2.5	3.1	3.66	50	110	346	59.0	1.25	1175	90.2	91.7	92.4	0.60	0.72	0.79	9.46	
10	7.5	256T	43.9	H	6.8	2.4	3.0	4.32	40	88	386	59.0	1.25	1180	91.0	92.4	92.4	0.62	0.74	0.80	12.7	
15	11	284T	65.9	H	7.1	2.6	3.0	7.69	25	55	474	59.0	1.25	1180	91.7	92.4	93.0	0.65	0.76	0.82	18.1	
15	11	284TS	65.9	H	7.1	2.6	3.0	7.69	25	55	474	59.0	1.25	1180	91.7	92.4	93.0	0.65	0.76	0.82	18.1	
20	15	284/6TS	87.8	J	7.4	2.7	3.0	9.29	20	44	538	59.0	1.25	1180	91.7	92.4	93.0	0.67	0.78	0.83	24.4	
25	18.5	324T	109	J	7.3	2.6	3.1	11.2	30	66	617	62.0	1.25	1185	92.4	93.6	94.1	0.61	0.73	0.80	30.8	
25	18.5	324TS	109	J	7.3	2.6	3.1	11.2	30	66	617	62.0	1.25	1185	92.4	93.6	94.1	0.61	0.73	0.80	30.8	
30	22	326TS	131	H	7.0	2.6	3.0	12.9	27	59	675	62.0	1.25	1185	92.4	93.6	94.1	0.60	0.73	0.80	36.7	
40	30	364/5TS	175	K	8.4	2.6	3.2	32.7	22	48	975	66.0	1.25	1185	93.6	94.5	95.0	0.64	0.76	0.81	48.9	
50	37	364/5TS	219	K	8.5	2.6	3.3	33.7	12	26	994	66.0	1.25	1185	93.6	94.5	95.0	0.63	0.75	0.81	60.3	

Mechanical Data

Frames 143T to 215T

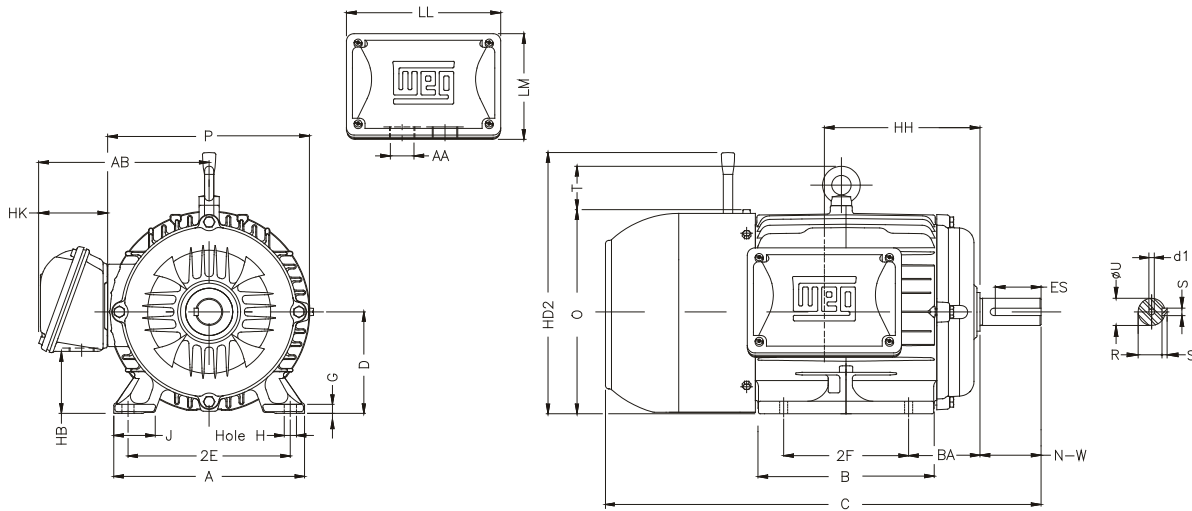

Frames 254T to 326T

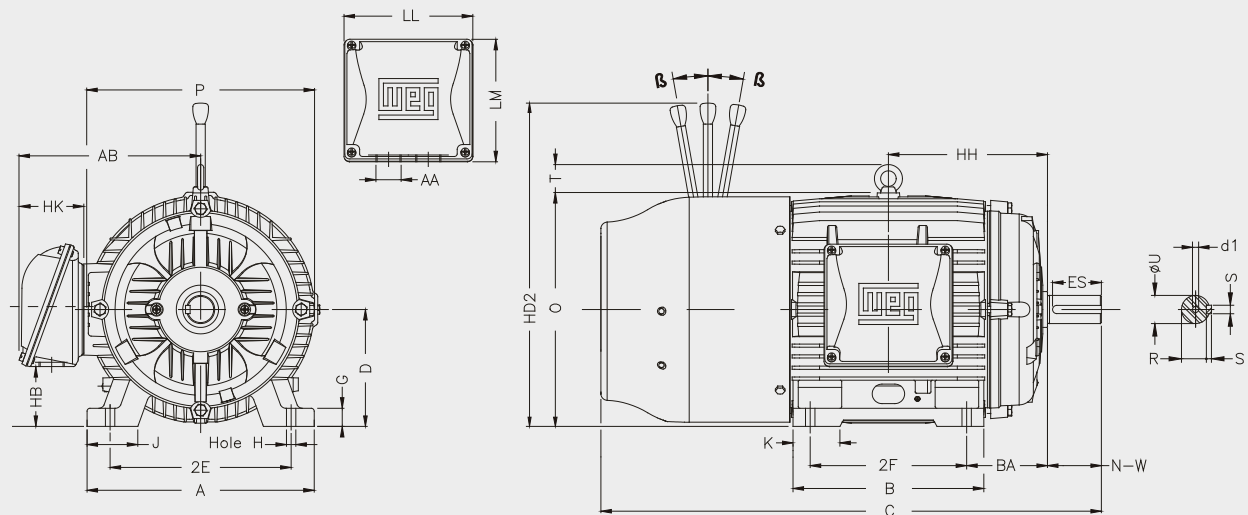

Frame 364/5T

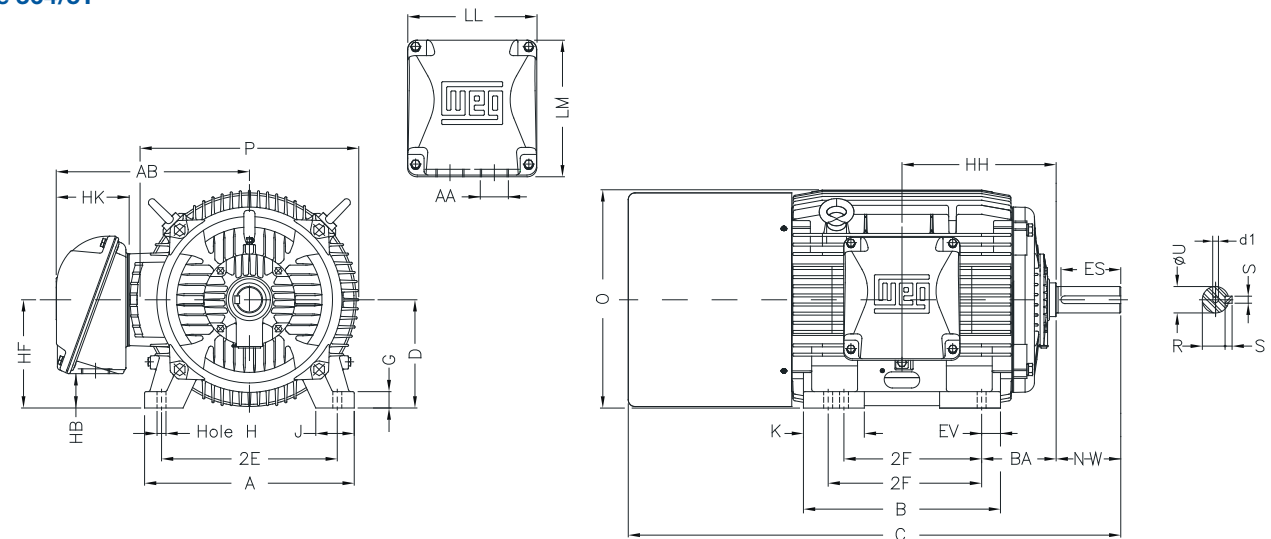

Frame	A	AA	AB	B	BA	C	D	G	Shaft																			
									U	N-W	ES	R	S															
143T	6.457	NPT 3/4"	6.263	5.157	2.250	15.169	3.500	0.354	0.875	2.250	1.575	0.771	0.187															
143/5T				6.142		16.231																						
145T				6.142		16.231																						
182T	8.661	NPT 1"	7.513	5.945	2.750	18.314	4.500	0.394	1.125	2.750	1.969	0.984	0.250															
182/4T				6.969		19.314																						
184T				6.969		19.314																						
213T	9.764		NPT 1"	8.609	7.362	3.500	21.688	5.250	0.669	1.375	3.375	2.480	1.203	0.313														
213/5T					8.858		23.188																					
215T					8.858		23.188																					
254T	12.126	NPT 1 1/2"		10.483	10.000	4.250	29.839	6.250	0.827	1.625	4.000	2.756	1.416	0.375														
254/6T					11.732										30.102													
256T					11.732											30.102												
284T	13.780		11.073	4.750	7.000	1.023	1.875	4.622	3.149	1.594	0.500																	
284TS							13.071	4.750	7.000	1.023	1.625	3.250	2.480	1.416	0.375													
286T											13.071	4.750	7.000	1.023	1.875	4.622	3.149	1.594	0.500									
286TS		13.071	4.750	7.000	1.023	1.625									3.250	2.480	1.416	0.375										
284/6T						13.071	4.750	7.000	1.023	1.875					4.622	3.149	1.594	0.500										
284/6TS										13.071	4.750	7.000	1.023	1.625	3.250	2.480	1.416	0.375										
324T	15.157	NPT 2"	12.575	5.250	8.000									1.300	2.125	5.250	3.937	1.844	0.500									
324TS						14.567	5.250	8.000	1.300						1.875	3.750	2.756	1.594										
326T										14.567	5.250	8.000	1.300		2.125	5.250	3.937	1.844										
326TS															14.567	5.250	8.000	1.300		1.875	3.750	2.756	1.594					
324/6T																				14.567	5.250	8.000	1.300	2.125	5.250	3.937	1.844	
324/6TS																								14.567	5.250	8.000	1.300	1.875
364/5T	17.165	NPT 3"	16.016	15.512	5.875									9.000					1.480									2.375
364/5TS						1.875	3.748	1.968	1.591																			0.500

Frame	Hole H	HB	HF	HH	HK	J	K	LL	LM	O	P	T	2E	2F	d1	Bearings		Manual release									
																D.E.	N.D.E.	HD2	β								
143T	0.344	1.727	3.500	4.250	2.733	1.437		5.961	4.215	7.122	7.047	-	5.500	4.000	A 4	6205 ZZ	6204 ZZ	8.697	9°								
143/5T				4.750										4.000/5.000													
145T				4.750										5.000													
182T	0.406	2.216	4.500	5.000	3.117	1.614		6.575	5.246	9.343	8.740	1.772	7.500	4.500	A 4	6207 ZZ	6206 ZZ	12.138	9°								
182/4T				5.500										4.500/5.500													
184T				5.500										4.500/5.500													
213T		2.966	5.250	7.000	6.250	1.772	2.165		6.575	5.246	10.841	10.669	1.772	8.500	5.500	A 4	6308 ZZ	6207 ZZ	14.659	10°							
213/5T					7.000										5.500/7.000												
215T					7.000										7.000												
254T	0.531	3.061	6.565	8.376	3.976	2.539	2.559	7.815	7.480	12.598	12.953	2.087	10.000	8.252	A 4	6309 C3	6209 C3	17.195	9°								
254/6T				9.250										8.252/10.000													
256T				9.250										10.000													
284T		3.535	7.000	10.250	9.500	3.071	3.583		7.815	7.480	14.067	14.173	2.087	11.000	9.500	A 4	6311 C3	6211 C3	19.563	10°							
284TS					10.250										11.000												
286T																					10.250	11.000					
286TS	10.250																						11.000				
284/6T																								10.250	11.000		
284/6TS																										10.250	11.000
324T		0.657	4.811	8.708		10.500	4.705	3.189	4.016	9.055	8.661	15.953	15.827	2.441		12.500	A 4	6312 C3	6212 C3	25.480							
324TS					11.250	10.500																					
326T															11.250						10.500						
326TS	11.250																					10.500					
324/6T																							11.250	10.500			
324/6TS																									11.250	10.500	
364/5T		0.660	4.251	9.000			12.362	6.024	3.150	4.138	10.591	11.267	17.957	17.914		6.255	14.016	11.260/12.244	DUNC 3/4"-10	6314 C3							6314 C3
364/5TS					12.362																						

